

PROCHEM

PEAK GTX

MOBILE CLEANING UNIT

Operating Instructions (ENG)

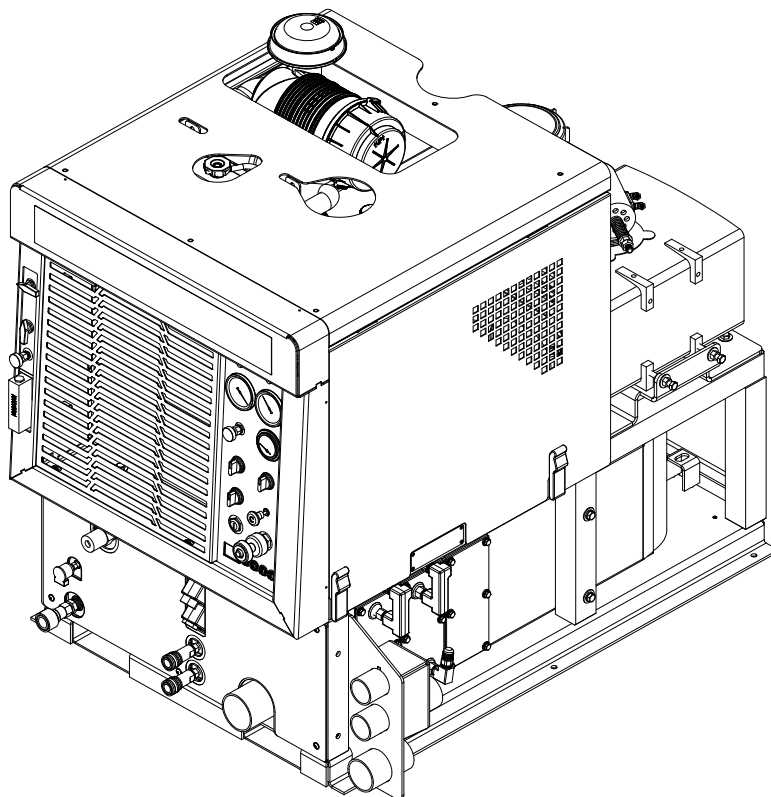

MODELS: PEAK GTX
1.001-132.0

Read instructions before operating the machine.

86325860 - A
06/08/09

Left intentionally blank

Model: _____
Date of Purchase: _____
Serial Number: _____
Dealer: _____
Address: _____
Phone Number: _____
Sales Representative: _____

Welcome...and congratulations on the purchase of your Mobile Cleaning Unit. This instruction manual is a guide for operating and servicing your unit. **Read this manual completely before installing or operating this unit.** This unit offers you personal convenience. All of your instrumentation and controls have been positioned to give you easy access for operation and daily maintenance.

Proper operation and service are essential to the efficient functioning of this unit. When maintained correctly, this unit will have a long, trouble-free life.

The service methods described in this manual are explained in such a manner that servicing may be performed accurately and safely. Proper service varies with the choice of procedure, the skill of the mechanic, and the tools or parts available. Before attempting any repair, make certain that you are thoroughly familiar with this equipment and are equipped with the proper tools. Any questions pertaining to operating or servicing this unit should be directed to your nearest dealer.

THIS UNIT MUST BE INSTALLED BY THE DEALER FROM WHOM YOU PURCHASED IT IN ACCORDANCE WITH THE PRESCRIBED INSTALLATION PROCEDURES.

MAKE CERTAIN THAT THE WARRANTY CARD IS FILLED OUT AT THE TIME OF INSTALLATION AND IS RETURNED TO YOUR DEALER.

PROFESSIONAL CHEMICALS CORPORATION
325 SOUTH PRICE ROAD
CHANDLER, ARIZONA 85224

Information in this document is subject to change without notice and does not represent a commitment on the part of Professional Chemicals Corporation.

Table of Contents

Machine Data Log / Overview	1
Table of Contents	2
Receiving Your Unit	4
Dealer Responsibility	4
Acceptance of Shipment	4
Equipment List	4
How to Use This Manual	5

Safety

IMPORTANT SAFETY INSTRUCTIONS	6
Safety Labels	8

Operations

Technical Specifications	9
Installation Requirements	10
Fuel Requirements	10
Engine Oil Requirements	10
Altitude Requirements	10
Chemical Requirements	11
Water Requirements	11
Hard Water Map	11
Controls	12
Vacuum System	15
Water Pumping and Heat Transfer System	16
Chemical Injection System	18
Pre-Run Inspection	19
Priming the Chemical Pump	20
Waste Pumpout (Optional)	20
Cleaning	20
Upholstery Cleaning	21
Shutdown and Daily Maintenance	21
De-flooding operations	21
Freezing Protection	21
Winterizing Your Unit	22
Removing Anti-Freeze From the Unit	23

Maintenance

Service Schedule	24
Key Checkpoints	26
Engine Coolant System (Radiator) Maintenance ..	26
External Fuel Pump Maintenance	26
Chemical Supply System Maintenance	26
Heat Exchanger System Maintenance	26
Vacuum Pump Maintenance	26
Engine	27
Vacuum Pump	28
Water Pump	29
Water Pump Clutch	29
Vacuum Inlet Filter (In Waste Tank)	29
Vacuum Relief Valve	29
Vacuum Pump Drive Belts	29
Water Pump Drive Belt	30
Float Valve (Water Box)	30
Waste Tank Float Valve	30
Waste Tank Strainer Basket	30
Waste Tank Vacuum Inlet Filter	30
Solution Screen (Outlet)	30
Check Valve (Outlet)	30
Chemical Pump	31
Chemical And Temperature Control Valves	31
Pressure Regulator	31
Vacuum Hoses	31
Solution Pressure Hoses	31
Optional Waste Pump-Out	31
Engine Coolant Replacement	31
General Service Adjustments	32
Engine Speed	32
Check Valve (Solution Outlet)	32
Water Box	32
Chemical Pump	32
Drive Belts For Water Pump and Vacuum Pump ..	32
Packing Nut Adjustments For Chemical Valves ..	33
Pressure Regulator	33
Troubleshooting	34

PARTS

Frame	40
Side Panel.	46
Chemical Panel.	48
Control Panel	50
Engine.	52
Vacuum Pump	56
Solution Pump.	58
Water Pump	60
Vacuum / Exhaust Heat Exchanger and Silencer.	62
Heli-Coil Heat Exchanger	64
Solution Outlet	66
Water Box	68
Regulator	70
Hose Accessories	72
60 Gallon Waste Tank	74
100 Gallon Waste Tank	76
Battery Floor Mount	78
Exhaust.	80
Heater Core - 3rd - Optional	82
Automatic Pumpout - Optional	84
Wand - Titanium Six Jet - Optional	88
Wand - Ergo Titanium Six Jet - Optional.	90
Wand - Quad Jet - Optional	92
Wand - Tri Jet -Optional	94
Stair Tool - Optional	96
Upholstery Tool - Optional	98
Shelf Assembly - Optional.	100
Water Tank Dual with Demand Pump - Optional	102
Water Tank - Demand Pump - Optional	104
Auxiliary Water Tank with Pump.	106
Hose Reel - Optional.	108
Wiring Diagram	110
Hose Diagram	111

Dealer Responsibility

The dealer from whom you purchased this mobile cleaning unit is responsible for the correct installation of this machine. The dealer is also responsible for initial training of your operators and maintenance personnel in the proper operation and maintenance of this unit.

Acceptance of Shipment

Every part of your cleaning unit was carefully checked, tested, and inspected before it left our manufacturing plant. **Upon receiving the unit, make the following acceptance check:**

1. The unit should not show any outward signs of damage. If damaged, notify the common carrier immediately.
2. Check your equipment and packing list. The standard cleaning unit should arrive equipped with the following items (unless otherwise specified) and any optional accessories which were ordered:

Equipment List

1. Console.
2. Waste tank
3. Hose clamps for vacuum hoses.
4. 100 ft. of 2" vacuum hose.
5. 1 vacuum hose connection.
6. 100 ft. of 1/4" solution pressure hose with quick connects.
7. 50 ft. water supply hose with quick connect.
8. Installation bolting kit.
9. Installation mounting plates.
10. Operation and service manual for engine, water pump, and vacuum pump.

Each unit will require a fuel system installation kit that is purchased separately from the unit.

This manual contains the following sections:

- How to Use This Manual
- Safety
- Operations
- Maintenance & Service
- Parts List

The HOW TO USE THIS MANUAL section will tell you how to find important information for ordering correct repair parts.

Parts may be ordered from authorized dealers. When placing an order for parts, the machine model and machine serial number are important. Refer to the MACHINE DATA box which is filled out during the installation of your machine. The MACHINE DATA box is located on the inside of the front cover of this manual.

Model: _____

Date of Purchase: _____

Serial Number: _____

Dealer: _____

Address: _____

Phone Number: _____

Sales Representative: _____

The model and serial number of your machine is located approximately where shown.

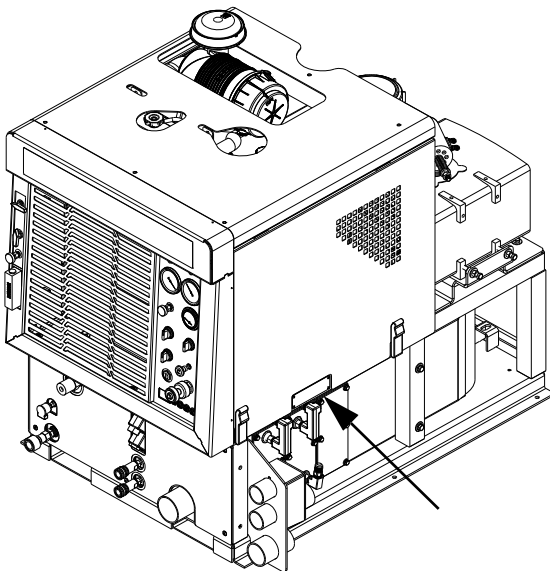

The SAFETY section contains important information regarding hazardous or unsafe practices of the machine. Levels of hazards are identified that could result in product damage, personal injury, or severe injury resulting in death.

The OPERATIONS section is to familiarize the operator with the operation and function of the machine.

The MAINTENANCE section contains preventive maintenance to keep the machine and its components in good working condition. They are listed in this general order:

- Engine
- Vacuum Pump
- Water Pump
- Drive Belts, Pulleys & Hubs
- Chemical Pump
- Hoses
- Vac / Exhaust Heat Exchanger
- General Service Adjustments
- Machine Troubleshooting

The PARTS LIST section contains assembled parts illustrations and corresponding parts list. The parts lists include a number of columns of information:

- **REF** – column refers to the reference number on the parts illustration.
- **PART NO.** – column lists the part number for the part.
- **PRV NO.** – reference number.
- **QTY** – column lists the quantity of the part used in that area of the machine.
- **DESCRIPTION** – column is a brief description of the part.
- **SERIAL NO. FROM** – If this column has an (*) and a Reference number, see the SERIAL NUMBERS page in the back of your manual. If column has two asterisk (**), call manufacturer for serial number. The serial number indicates the first machine the part number is applicable to. The main illustration shows the most current design of the machine. When a boxed illustration is shown, it displays the older design.
- **NOTES** – column for information not noted by the other columns.

NOTE: If a service or option kit is installed on your machine, be sure to keep the KIT INSTRUCTIONS which came with the kit. It contains replacement parts numbers needed for ordering future parts.

NOTE: The manual part number is located on the lower left corner of the front cover.

IMPORTANT SAFETY INSTRUCTIONS

When using this machine, basic precaution must always be followed, including the following:
READ ALL INSTRUCTIONS BEFORE USING THIS MACHINE.

! WARNING:

These symbols mean **WARNING** or **CAUTION**. Failure to follow warnings and cautions could result in fatality, personal injury to yourself and/or others, or property damage. Follow these instructions carefully!

! CAUTION:

Read the operator's manual before installing or starting this unit. Failure to adhere to instructions could result in severe personal injury or could be fatal.

Operate this unit and equipment only in a well-ventilated area. Exhaust fumes contain carbon monoxide which is an odorless and deadly poison that can cause severe injury or fatality. **DO NOT** run this unit in an enclosed area. **DO NOT** operate this unit where the exhaust may enter any building doorway, window, vent, or opening of any type.

Gasoline is extremely flammable and its vapors can explode if ignited. Store gasoline only in approved containers, in well-ventilated, unoccupied buildings away from sparks or flames. Never carry any gasoline or flammable material in the vehicle. Fumes may accumulate inside the vehicle and ignite, causing an explosion.

DO NOT store any type of flammable material in the vehicle.

This unit must be operated with the vehicle or trailer doors open in order to ensure adequate engine ventilation.

DO NOT operate engine if gasoline is spilled. Avoid creating any ignition until the gasoline has been cleaned up. Never use gasoline as a cleaning agent.

DO NOT place hands, feet, hair, or clothing near rotating or moving parts. Avoid any contact with moving parts! Rotating machinery can cause injury or fatality.

Never operate this unit without belt guards or hoods. The high speed moving parts, such as belts and pulleys, should be avoided while this unit is running. Severe injury, damage, or fatality may result.

DO NOT service this unit while it is running. The high-speed mechanical parts as well as high temperature components may result in severe injury or severed limbs.

Never touch electrical wires or components while the engine is running. They can be sources of electrical shock.

Engine components can get extremely hot from operation. To prevent severe burns, **DO NOT** touch these areas while the engine is running - or immediately after the engine is turned off.

DO NOT touch the exhaust system while this unit is running. Severe burns may result.

Before servicing this unit, allow it to "cool down." This will prevent burns from occurring.

Water under high pressure at high temperature can cause burns, severe personal injury, or fatality. Shut down machine, allow to cool down, and relieve system of all pressure before removing valves, caps, plugs, fittings, filters, and bolts.

Always wear hearing protection when unit is running. Always comply with local noise ordinance when operating units.

DO NOT leave the vehicle engine running while operating this unit.

Dangerous Acid, Explosive Gases! Batteries contain sulfuric acid. To prevent acid burns, avoid contact with skin, eyes and clothing. Batteries produce explosive hydrogen gas while being charged. To prevent a fire or explosion, charge batteries only in well ventilated areas. Keep sparks, open flames, and other sources of ignition away from the battery at all times. Keep batteries out of the reach of children. Remove all jewelry when servicing batteries.

Before disconnecting the negative (-) ground cable, make sure all switches are OFF. If ON, a spark will occur at the ground cable terminal which could cause an explosion if hydrogen gas or gasoline vapors are present. When disconnecting the battery, **ALWAYS** disconnect the negative (-) terminal **FIRST**.

DO NOT smoke around the unit. Gas fumes may accumulate and be ignited. The battery is also extremely flammable. This will help to prevent possible explosions.

DO NOT damage the vehicle in any manner during installation. When routing fuel lines **DO NOT** place the hose in any location where damage may occur to the hose or vehicle. Avoid any contact with moving parts, areas of high temperature, brake lines, fuel lines, muffler, catalytic converter, or sharp objects.

Use only ProChem supplied fuel installation kits. Ensure to use the kit specific for the truckmount model and van model being used. When traversing the vehicle floor with fuel lines, always use a bulkhead adapter. This will help to prevent leakage and ensure that the hose is not punctured by vehicle vibration abrasion.

DO NOT exceed your vehicle's weight limit. The console with waste tank and accessories weighs approximately 1014 lbs. Make certain to account for any additional accessories in your weight and balance calculations. Make certain that the vehicle has the correct axle rating, to prevent unsafe vehicle driving conditions.

We require high-back seats on all vehicles in which units are to be installed for head and neck protection. We recommend using a metal partition between the seats and equipment.

DO NOT operate this unit without the water supply attached and turned on. The water pump and other vital components may be seriously damaged if this unit is permitted to operate dry without water. Running with out adequate water supply could damage water pump. Ensure always to have an adequate water supply.

DO NOT operate this unit without the filter installed in the waste tank.

Keep your vehicle work area clean. Wands, stair tools, and other accessories must be securely fastened before driving the vehicle.

All high pressure hoses must be rated for 3000 PSI at 250°F. Thermoplastic hoses do not meet these specifications and should not be used. Severe burns and injury may result if the hoses do not meet these requirements.

The winterizing loop hose assembly, Part #86260700, PRV NO. 10-805380, is for winterizing use only. If used improperly, live steam may escape from this hose, causing it to whip around. Burns or injury may result.

Make certain that you receive complete training by the distributor from whom you purchased this unit.

This unit uses high pressure and temperature. Improper or irresponsible use may result in serious injury.

Do not modify this unit in any manner. Improper modification can cause severe personal injury or fatality.

CALIFORNIA PROPOSITION 65 WARNING: Engine exhaust from this product contains chemicals known to the State of California to cause cancer, birth defects, or other reproductive harm.

Safety Labels

The following **WARNING LABELS** are found on your cleaning unit. These labels point out important **Warnings** and **Cautions** which should be followed at all times. Failure to follow warnings and cautions could result in fatality, personal injury to yourself and/or others, or property damage. Follow these instructions carefully! **DO NOT** remove these labels.

NOTE: *If at any time the labels become illegible, promptly replace them.*



Warning Label
86186520
PRV NO. 500769

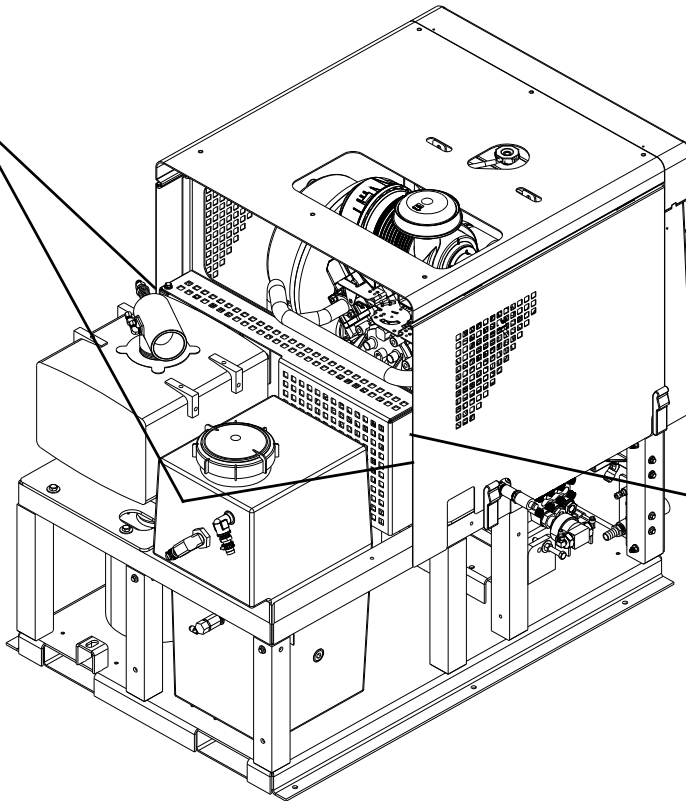

Caution label
86186530
PRV NO. 500770

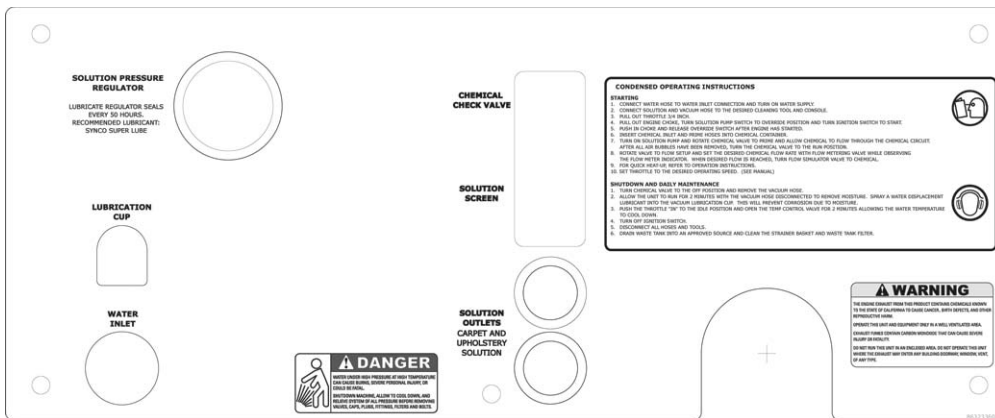

Front panel decal with warning labels
PRT NO. 86323360

Technical Specifications

ITEM	DIMENSION/CAPACITY
Engine speed	2850 rpm (high speed) Water Pump ON 1200 rpm (idle speed) Water Pump OFF.
Water pump rpm	1750 rpm
Vacuum pump rpm	3250 rpm
Water flow rate	3.5 GPM (maximum)
Water pump pressure (low pressure)	1000 PSI (maximum)
Vacuum relief valve	13" Hg
Waste tank capacity	60 gallons
Console weight	794 lbs.
Console weight (with waste tank & waste tank accessories)	1014 lbs.
TORQUE VALUES	
Engine hub	300 inch lbs 25 foot/lbs
Vacuum pump hub	300 inch/lbs 25 foot/lbs
Front engine pulley	216 inch/lbs 18 foot/lbs
Water pump clutch shaft bolt	300 inch/lbs 25 foot/lbs

JET SIZING:

Recommended **floor tool** tip sizing not exceed a total of ".045". Using larger jet sizes on your cleaning unit may reduce cleaning temperatures.

Example: **Tri-jet wand uses three 95015 jets** (95° spray angle w/ 015 orifice).
 015 X 3 = 045

Upholstery tool jet size: **80015**

Stair tool jet size: **9502**

Installation Requirements

NOTE: *Your dealer from whom you purchased this mobile cleaning unit is responsible for the correct installation of this machine. The dealer is also responsible for initial training of your operators and maintenance personnel in the proper operation and maintenance of this unit.*

1. The unit should NOT be mounted in any motor vehicle of less than 3/4 ton capacity.

CAUTION:

The console with waste tank and accessories must NOT exceed the vehicle's axle weight limit.

2. If mounting in a trailer, make certain that the trailer is rated for the total weight of the UNIT AND TRAILER. Electric or hydraulic brakes should be provided, and a strict compliance with any State and Federal vehicle laws must be maintained.
3. The vehicle tires should have a load rating above the combined vehicle and unit weight.
4. We do not recommend using flooring materials that absorb water. This could result in rust and corrosion of the vehicle floor.
5. Padding under rubber floor mats should be removed before installing this unit.
6. We highly recommend using a aluminum drip tray under the console (Part #86055040, PRV NO. 790552).
7. If using a trailer, the console should be positioned so that it balances properly with respect to the axle. Ten percent (10%) of the total trailer weight, not exceeding 800 lbs, should be on the tongue. Load the unit and accessories appropriately.

Fuel Requirements

Use unleaded gasoline ONLY. DO NOT use any gasoline additives. We recommend the use of clean, fresh, unleaded gasoline intended for automotive use. High octane gasoline should **NOT** be used with the engine on this unit. These engines are NOT designed to use E-85 or Flex Fuels.

Engine Oil Requirements

Use high quality detergent 10W-30 oil of at least API (American Petroleum Institute) service class SG, SH, SJ or higher.

NOTE: *Using a lower service class oil or extending oil change intervals longer than recommended can cause engine damage.*

NOTE: *Synthetic oils meeting the listed classifications may be used with oil changes performed at recommended intervals. However to allow piston rings to properly seat, a new or rebuilt engine should be operated for at least 50 hours using standard petroleum based oil before switching to synthetic oil.*

Altitude Requirements

Engines perform differently with increases/decreases in altitude. Be sure to check engine speeds during initial installation. See engine speeds in Technical Specifications section.

NOTE: *To ensure correct engine operation at altitudes above 1525 meters (5000 ft.), it may be necessary to have an authorized Kohler dealer install a special high altitude jet kit in the carburetor. If a high altitude kit has been installed, the engine must be reconverted to the original jet size, before it is operated at lower altitudes, or overheating and engine damage can result.*

Chemical Requirements

The unit, due to its chemical injection pump design, can be used with a variety of water-diluted chemical compounds (either acidic or alkaline), depending on the job to be done. However, to obtain optimum results with this unit, we recommend using the Prochem line of chemicals. For information on using the cleaning compounds, refer to the chemical manual.

Water Requirements

Hard water deposits will adversely affect the plumbing and heat exchange systems on this unit. The map below will give you an idea of where areas of high water hardness may occur. However, any water supply obtained from a well is almost always hard water and a water softener will be needed to protect your equipment.

NOTE: *Equipment malfunction or component failure caused by hard water scaling is NOT covered under the warranty.*

If you are operating this unit in an area where the unit will be using water in which the hardness exceeds 3-1/2 grains, we highly recommend a suitable water softener be installed. If using a water softener, it must have a five (5) GPM (or greater) flow capacity without any hose constrictions.

Using a water softener will reduce maintenance and decrease down time caused by hard water scaling. It will also allow cleaning chemicals to be more effective in lower concentrations.

If you require a water softener, your dealer has a model to meet your needs. Please contact your nearest distributor for information, price, and availability.

Hard Water Map

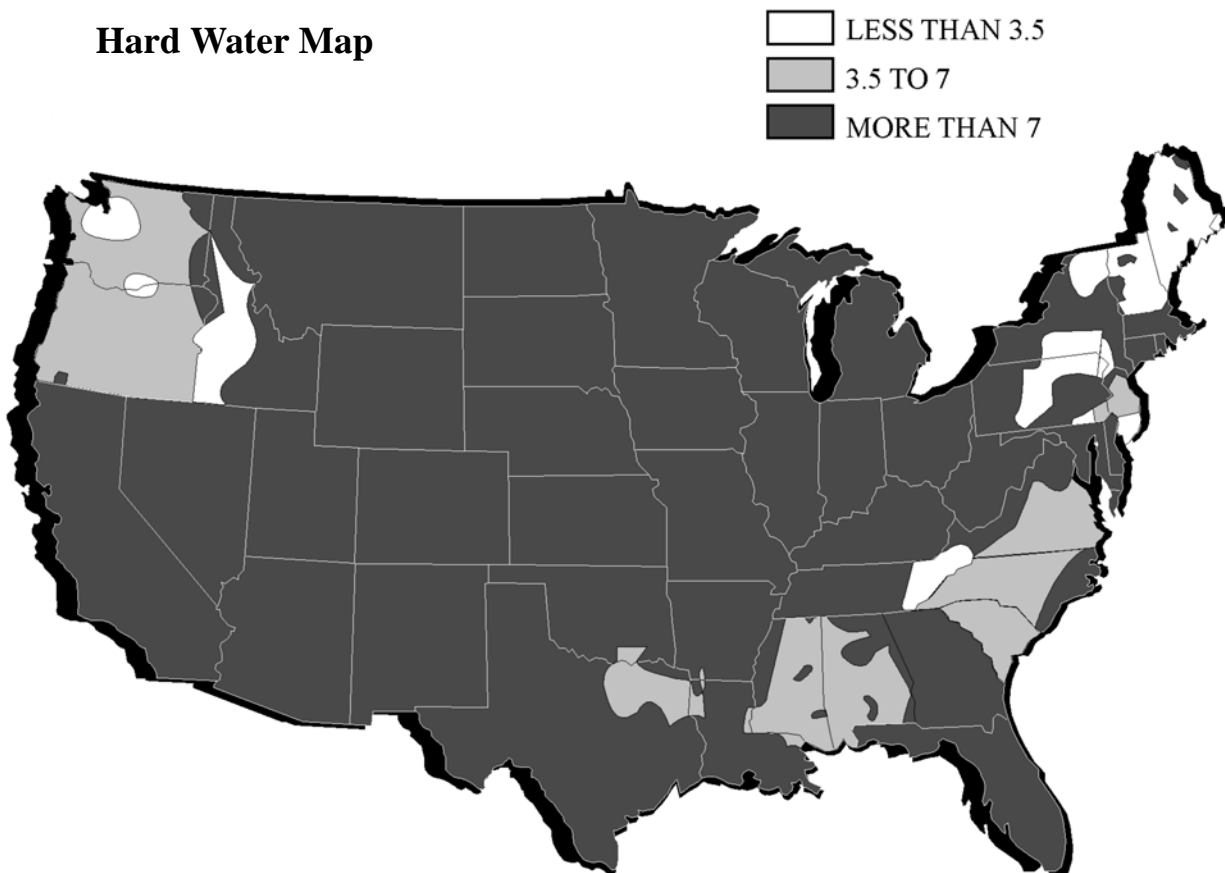

Controls

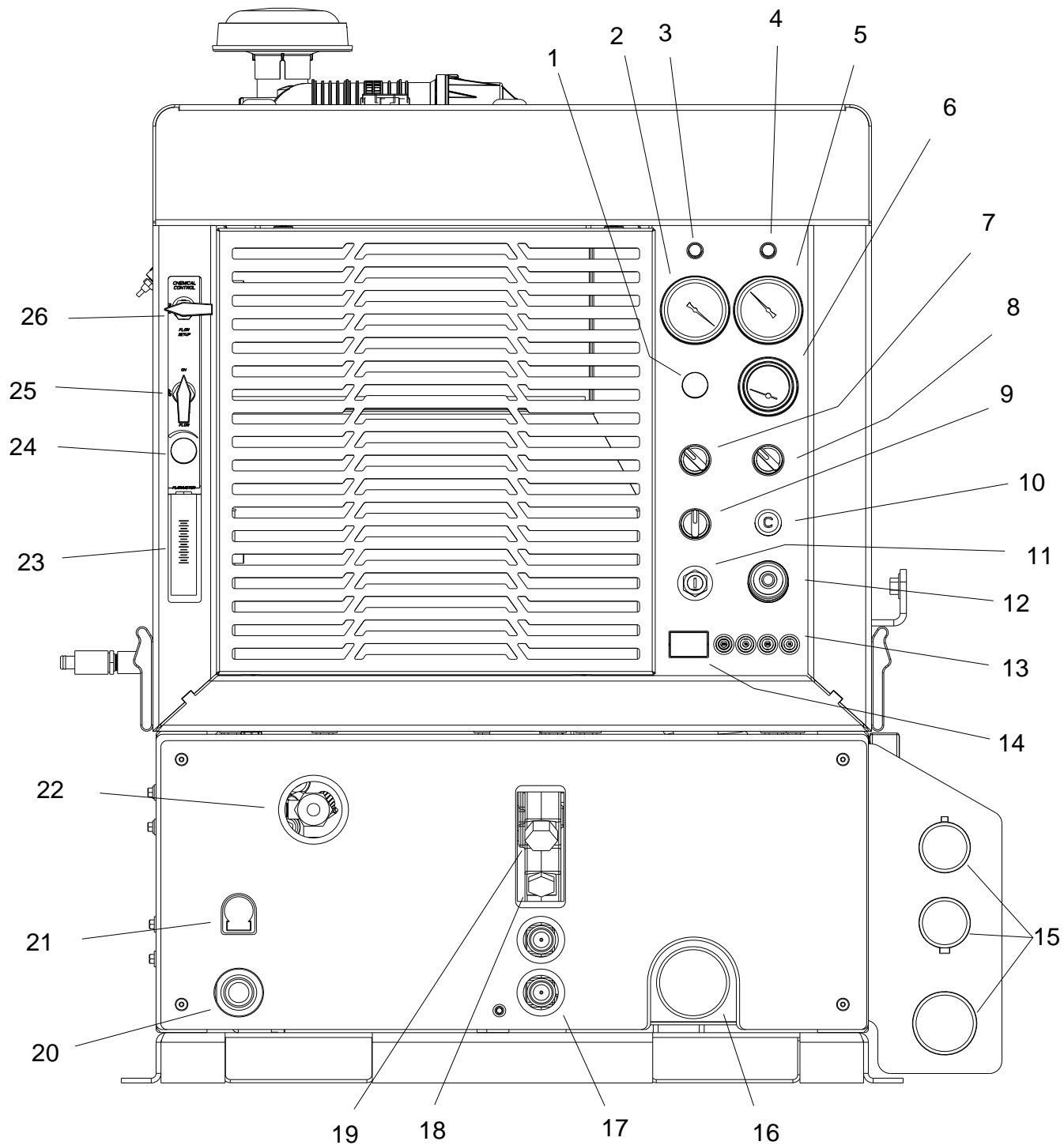

1. **Solution Temp Control Valve**

This valve allows the operator to control the solution temperature by bypassing hot water to the waste tank, for low temperature cleaning such as upholstery. Turning the valve counter clockwise opens the valve. Turning clockwise closes the valve and has the effect of stopping water from bypassing.
2. **Vacuum Gauge**

This gauge indicates in inches of mercury how much vacuum the system is producing at any given time.
3. **Waste Tank Full Indicator Light**

This indicator light is activated when the waste tank is full. When lit the unit will shutdown protecting the equipment from damage. This also indicates that the waste tank must be emptied before the unit can be brought back in service.

NOTE: *Never dispose of waste water in storm drains, water ways or on ground areas. Always dispose of waste in accordance with local state and federal laws.*
4. **Engine High Temperature Shutdown Indicator**

This light when activated signals an over heat condition with the engine. When this occurs, troubleshooting is required.
5. **Solution Pressure Gauge**

This gauge registers the amount of pressure in the system.
6. **Solution Temperature Gauge**

This gauge measures the temperature of the cleaning solution as it exits the machine.
7. **Auxiliary Water Tank Pump Switch**

The auxiliary water tank pump switch is used to actuate the (optional) fresh water demand pump.
8. **Waste Pumpout Switch**

This switch actuates the (optional) waste pumpout.
9. **Solution Pump Switch**

This switch serves to energize the magnetic clutch to turn the water pump on or off. Turn clockwise for activating the pump and counter clockwise for deactivating the pump.
10. **Choke**

The choke cable is for restricting air to the carburetor, this enriches the fuel mixture. The primary purpose is for starting in cold temperatures. When the cable is pulled out air is restricted, when pushed in the engine is in run position.

WARNING: Do **NOT** run engine with choke pulled out.
11. **Ignition Switch**

The key switch controls the power for the machine. To turn the machine on, rotate the key clockwise while holding solution pump switch to override position until the starter engages the engine. When machine is running let off the switch and engine will continue to run. To turn power off, rotate key counter clockwise to stop position, engine will then stop.
12. **Throttle**

The throttle cable is used to set the speed of the engine (rpm). The engine speed (rpm) may be increased by releasing the collar lock, pushing in the red button on the end of the handle, and pulling the handle straight out. Engine speed may be changed in smaller increments by rotating the throttle handle clockwise or counter-clockwise. The collar lock can be tightened to prevent the throttle from slipping and changing the engine speed.
13. **Circuit Breakers**

These serve to protect the circuits from electrical spike and over loads and protects wires from damage and fire.
14. **Hour Meter**

The hour meter records the number of hours the unit has run. This serves as a time recorder for servicing the machine.

15. Vacuum Inlet(s)

The vacuum inlet(s) serve as connecting point(s) for vacuum hoses.

16. Exhaust

Exhaust fumes contain carbon monoxide which is an odorless and deadly poison that can cause severe injury or fatality. DO NOT run this unit in an enclosed area. DO NOT operate this unit where the exhaust may enter any building doorway, window, vent, or opening of any type

17. Solution Outlet(s)

The solution outlet(s) are the connecting point(s) for the solution pressure hoses. These outlet(s) have quick disconnects that allow hoses to be plugged into the unit.

18. Solution Screen

The solution screen is located on the front of the machine. The function of this screen is to trap foreign particles from exiting the machine and plugging the orifices of the cleaning tools. This screen is part of the machine maintenance cleaning.

19. Chemical Check Valve

The chemical check valve allows chemicals to enter the system and travel in a singular direction to the wand. The chemical check valve prevents chemicals from traveling up-stream into the solution system of the unit.

20. Water Inlet

This quick connect allows the water supply hose to be connected to the unit.

21. Lubrication Cup

The lubrication cup allows lubricant spray to reach the vacuum blower.

22. Pressure Control Regulator

The pressure regulator sets the pressure of the solution system. This spring loaded valve can be adjusted up or down. Turning the valve clockwise increases the units pressure. The pressure is reduced by turning the valve counter clockwise. This valve must be maintained in accordance with this manual's maintenance table.

23. Flow Meter

The flow meter is a gauge to indicate how much liquid chemical is being introduced in the water system. The quantity can be increased by turning the chemical flow knob counter clockwise.

24. Chemical Metering Valve

The chemical metering valve regulates the amount of chemical that is injected into the system. Clockwise rotation of the knob closes the valve. Counter clockwise rotation opens the valve, allowing more chemical to enter the system.

25. Chemical Prime Control Valve

This valve allows the chemical to circulate through the chemical system with little or no restriction. It also purges out air that may be trapped in the lines and cavities of the chemical pump. By turning the valve clockwise the injection system is enabled.

26. Flow Setup Valve

This valve allows solution to move through the machine and chemical to be injected simulating the cleaning process. This allows the operator to set the chemical flow level without connecting tools to the machine. It is also useful in troubleshooting.

Vacuum System

The engine turning a vacuum pump generates vacuum. The air is channeled in one side of the vacuum pump, compressed and discharged on the opposite side, creating airflow.

The movement of air is used to do the work necessary for the extraction process. A vacuum nozzle applied to the carpet surface removes moisture, dirt and spent chemicals. These elements are conveyed back to a separating tank utilizing hoses and the force of air. Particles of moisture and dirt are separated in the vacuum tank using a series of changes in direction and velocity. The air is then filtered and rushes into the vacuum pump.

The vacuum pump compresses and heats the incoming air. The hot discharged air is forced down stream into a silencer for noise abatement. After exiting the silencer, this hot air is mixed with hot air exhaust gases from the engine. This mixture of hot air and gases are then forced through 2 radiators serving as heat collectors. Heat from the engine and vacuum pump is then transferred into the plumbing system raising the water temperature for better cleaning.

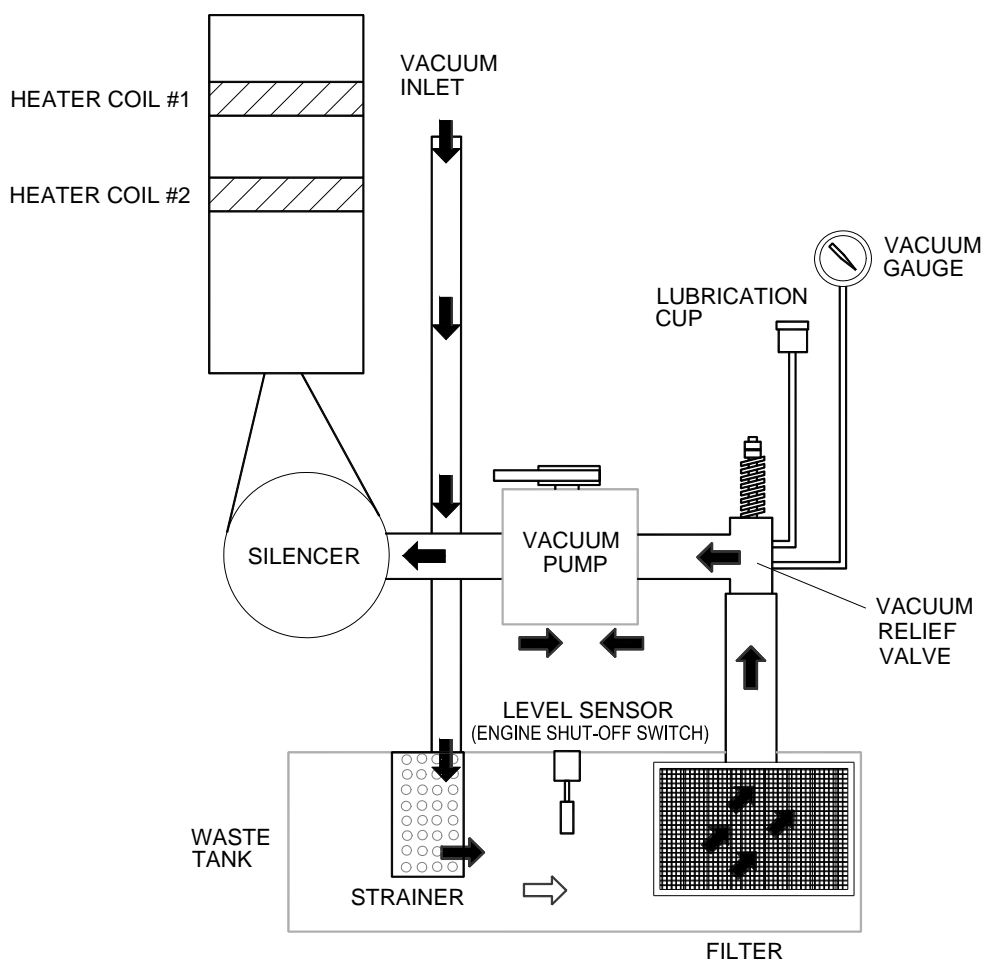

⚠ WARNING:

Always wear hearing protection and proper personal protection equipment when operating unit.

Water Pumping and Heat Transfer System

Cold water enters the console through the water inlet. When the water box is full the valve will automatically shut off.

Water then flows from the water box, through a strainer, into the water pump where it is pumped to the pressure regulator manifold where the pressure regulator maintains the desired pressure setting.

The pressure regulator manifold includes a pulse hose which helps reduce pressure spikes from the pump.

A certain amount of water is by-passed from the pressure regulator due to over pumping capacity of the water pump. Water that is not called for in the cleaning process is channeled through a heat exchanger box into the first heater core from the front of the unit. This bypass water may circulate several times through the bypass heat exchanger allowing the water to be pre-warmed.

The next stage of heating and water flow is to the helicoil, when water is called for in the cleaning process it flows to the helicoil under pressure. Heat from the engine coolant is exchanged to the cleaning solution through a series of spiraled copper tubing. This allows the engine coolant to travel in a counter rotating direction to the cleaning water during the exchange process creating a very efficient transfer of heat out of the engine and into the cleaning solution.

The third stage of plumbing and heat exchange takes place in the 2nd heater core located in the heater box. This is the hottest point of the gases coming from the vacuum pump and the engine exhaust. These hot gases are forced through heater core #2 creating the third stage of heat transfer to the cleaning solution.

Finally, the hot solution passes to the outlet manifold where cleaning chemicals are injected from the chemical pulse pump. This manifold serves as a temperature sensing point and the temperature control valve allows cooler water to enter the system for temperature sensitive upholstery applications. A check valve is located in this outlet manifold prohibiting chemicals from backing up into the system. Two connecting points for the high-pressure hoses are located at the end of the manifold.

The cleaning solution then passes through solution pressure hoses and is distributed by the cleaning tool to a surface that is being cleaned, completing the water pumping and heating cycle of the cleaning unit.

⚠ CAUTION:

Pump damage can occur if it is "thermal shocked." This may happen if the pump has run without the water supply turned on, allowing the pump to become over-heated, and then turning on the water supply which sends fresh cool water to the pump without having a sufficient cool down period. Thermal shock typically ruins the seals and cracks the ceramic plungers.

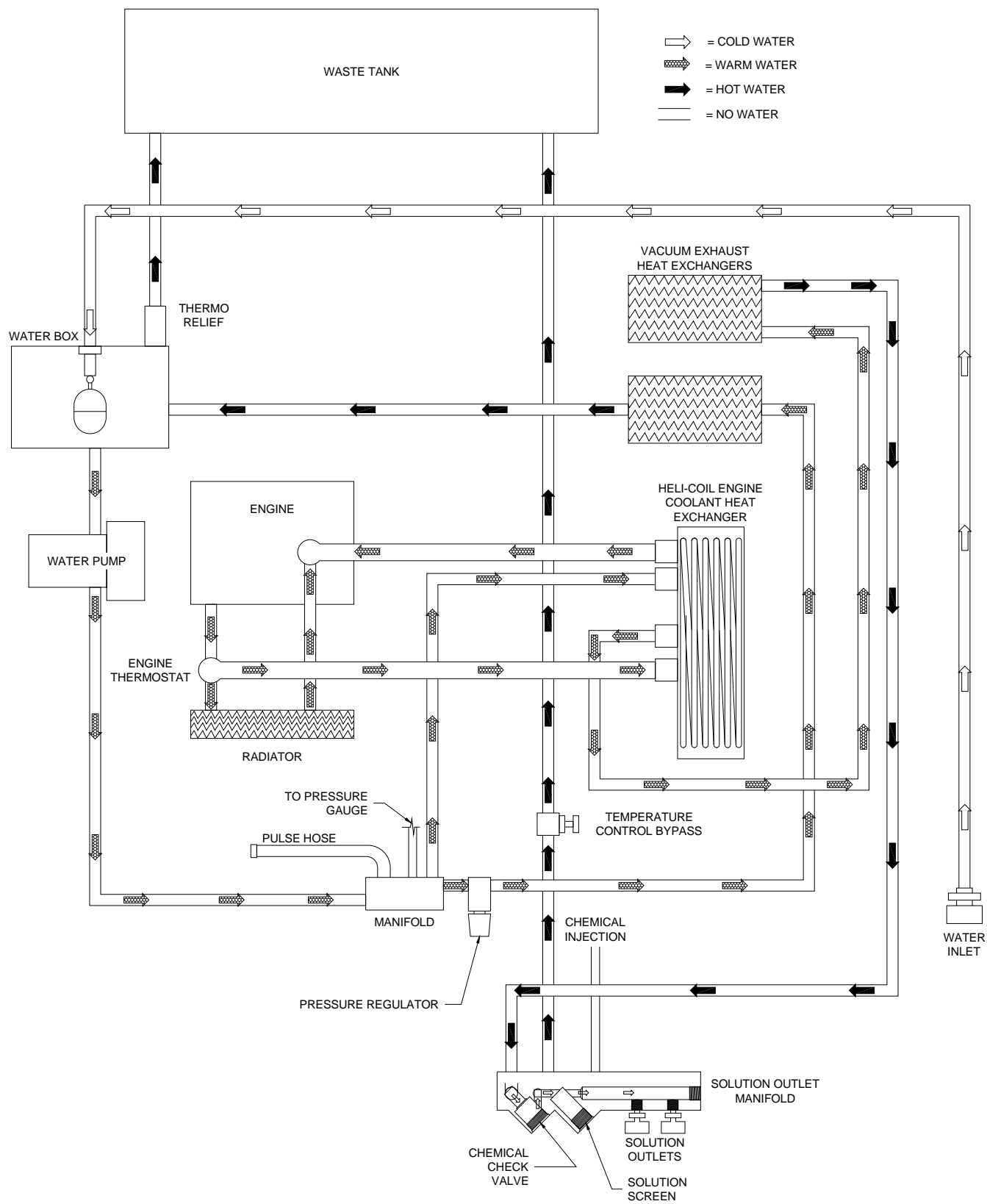

Chemical Injection System

The chemical injection system is unique in that it utilizes the pressure spikes generated by the high-pressure water pump to move chemical into the main solution stream. The high pressure spikes move the diaphragm in the chemical pulse pump forcing small amounts of liquid chemical to be moved in a single direction of flow with the aid of two check valves.

The chemicals are drawn from the container, and through the flow meter, which indicates rate of flow. The chemicals move to the chemical pulse pump where it is pressurized.

The chemicals flow to the chemical selector valve, which can turn off the chemical flow or when set to "Prime" sends it into the waste tank to purge air from the system, or when "CHEM" the chemical can be directed to the metering valve. The metering valve controls the amount of chemical that enters the solution outlet manifold.

The manifold assembly's check valve will not allow the chemicals to travel upstream into the plumbing system of the unit. The chemicals are mixed there with hot pressurized water that makes a cleaning solution. The flow setup valve is set to "Setup" while adjusting the chemical mix. This causes incorrectly mixed solution to safely drain to the waste tank until the manifold has the correct solution mix. Setting to "CHEM" lets the solution flow to the outlets for cleaning.

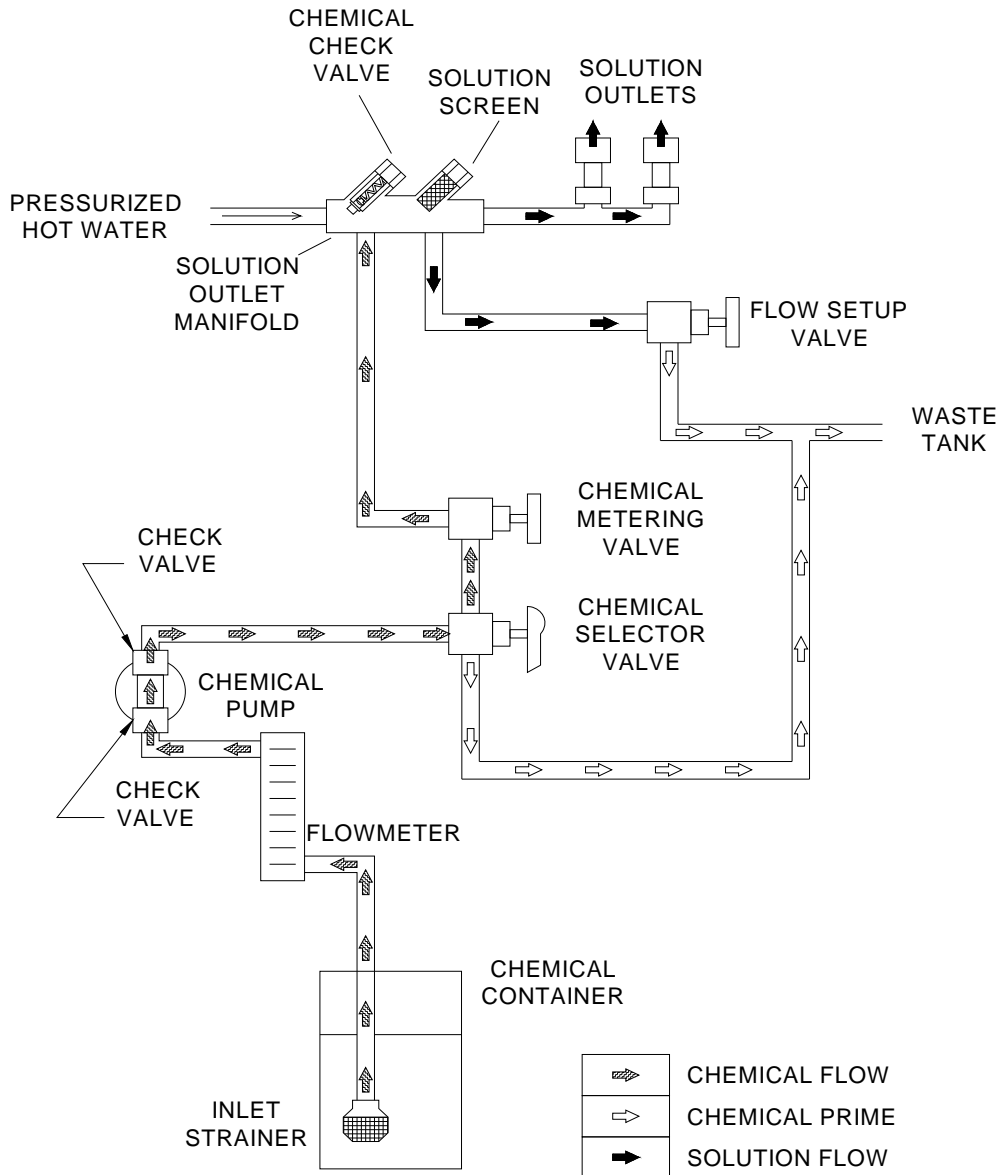

Pre-Run Inspection

NOTE: Operation of this unit is simple. However, only trained personnel should proceed.

! WARNING:

Operate this unit and equipment only in a well-ventilated area. Exhaust fumes contain carbon monoxide which is an odorless and deadly poison that can cause severe injury or fatality. DO NOT operate this unit where the exhaust may enter any building doorway, window, vent, or opening of any type.

Check for Adequate Fuel

Check the fuel tank to be certain there is adequate fuel to complete the job. This unit uses approximately 0.75-1.00 gallons of fuel per hour, depending on the speed setting.

Remove Tools from Vehicle

Remove any tools or hoses from the van which you will require.

Water Supply Connection

NOTE: Before connecting your water hose to the supply faucet, flush out the faucet until the water is free of any debris. Flush out any debris which may be in your water inlet hose.

1. Connect the water supply hose to the water inlet quick-connect at the left front of the console. Connect the hose to the water supply faucet.

NOTE: Never use your waste pump outlet hose as a water inlet hose. Use only clean hoses for water inlet.

2. Turn the water supply faucet on. The water will fill the water box.

Solution Pressure Hose

Before starting the unit, connect the solution pressure hose to the outlet connection at the front of the unit. Connect the cleaning tool to the pressure hose.

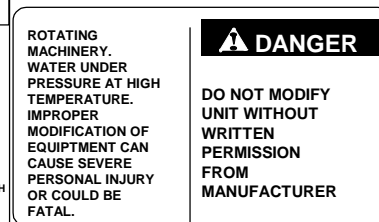
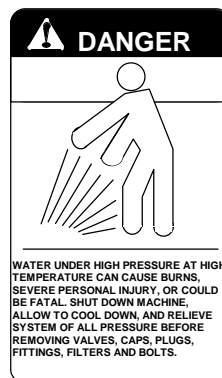

Vacuum Hose

Connect the vacuum hose to the vacuum inlet connection at the front of the unit. Connect the other end of the vacuum hose to the cleaning tool.

Filters

Ensure all filters on machine and in waste tank are free of debris.

Priming the Chemical Pump

1. Fill chemical container and inspect chemical filter.
2. Insert chemical inlet tubing into chemical container.
3. Pull out engine choke, turn solution pump switch to override, and turn ignition key to start.
4. Push in engine choke after engine has started.
5. Set throttle to idle position.
6. Turn on the solution pump.
7. Turn chemical valve to prime and allow chemical to circulate. After all air bubbles have been removed from chemical tubing, turn the valve to Chem position. Turn chemical flow setup valve to setup position. Set the chemical flow to the desired flow rate with the metering valve. Turn the chemical flow setup valve to Chem position.
8. Set throttle to maximum position with vacuum port partially blocked off for quick unit heat up.

Waste Pumpout (Optional)

1. If your unit is equipped with an automatic waste pump, connect one end of a garden hose to the pump-out connection and the other end to an appropriate waste disposal.
2. Turn the pump-out switch on the control panel to the ON position. The waste pump will operate automatically throughout the cleaning operation.

We recommend that you use a 3/4" I.D. water hose as a waste pump outlet hose. DO NOT use a hose smaller than 5/8" I.D.

NEVER use your automatic waste pump outlet hose as a water inlet hose.

WARNING:

NEVER dispose of waste in storm drains, waterways, or on ground areas. Always dispose of waste in accordance with Local, State, and Federal laws.

Once you have completed priming the chemical pump, proceed with the cleaning operation. Your unit should be in the correct throttle position for your cleaning operation or extracting. A float switch located inside the waste tank will automatically shut down the unit when it reaches its full capacity. When this occurs, empty the waste tank before continuing.

Cleaning

Observe the following guidelines, while cleaning:

1. Before proceeding make sure the spray tips are functioning properly.
 - a. To check, hold the wand about one foot above the surface to be cleaned and open the wand valve. A full spray should be observed from all of the cleaning spray tips.
 - b. If the spray tips are not showing a full spray pattern, adjust spray tips for proper pattern, clean, or replace spray tips, if required.
2. Normally chemical is applied on the push stroke of the wand when cleaning and vacuuming is done on the pull stroke. For heavily soiled carpets the wand may be used in a scrubbing manner, apply chemical in both push and pull strokes. Always finish up an area with a vacuum stroke.
3. When cleaning, keep the working opening (mouth) flat on the surface being cleaned. Keep the wand moving when the valve is open.
4. The unit will automatically shut-down when the waste tank is full. This will prevent water being drawn into the vacuum pump. If shut-down occurs, empty the waste tank before proceeding.

Upholstery Cleaning

Upholstery tool, part #86285260, PRV NO. 78513

1. To protect fabrics, reduce solution temperature as needed by opening the solution temp control valve on the control panel. Engine speed may also be reduced slightly to reduce heat and vacuum.
2. Use one (1) "86229980, PRV NO. 80015" spray tip in tool.

Shutdown and Daily Maintenance

1. Turn chemical valve to "NO CHEM".
2. Allow the unit to run for 2 minutes with the vacuum hose disconnected to remove moisture. Spray water displacing lubricant into the vacuum lubrication cup and cover the vacuum inlet to draw the water displacing lubricant into the blower. This will prevent corrosion due to moisture.
3. Set engine throttle at idle position and allow the water temperature to cool down, utilizing the solution temp control valve in the open position to bleed off residual hot water left in the system.
4. Close solution temp control valve and turn off ignition switch.
5. Disconnect all hoses and tools.
6. Drain waste tank and rinse with clean water.

De-flooding operations

De-flooding operations involve removal of water from carpet and flooring. This differs from normal cleaning operations in that no water or solution is required. An automatic waste pump-out is highly recommended for all de-flooding operations due to the large amount of water removal often required.

1. Start unit.
2. Set pressure regulator at 100 psi.
3. Shut off solution pump.
4. Begin de-flooding operations.
5. Under almost all conditions, the unit will sufficiently cool itself. If you find yourself operating in extreme heat, attach a clean fresh water supply to unit. Turn solution pump on and open solution temperature control valve at least one full turn.

Freezing Protection

CAUTION:

*If the unit is exposed to freezing weather the water in the unit may freeze, causing **SERIOUS DAMAGE** to the unit. To avoid this, the following is recommended during the cold weather season.*

When the unit is not in use, always park it in a heated building.

While in operation, avoid long shutdowns as the unit provides heat while running. Shut it down just prior to leaving for the next job.

If a heated building is not available, we recommend that you winterize the unit with anti-freeze. At present, it is only possible to winterize units, which do not have an auxiliary water tank. Units with auxiliary water tanks must be stored in a heated building when not in use.

Winterizing Your Unit

1. Shut off the water supply. Disconnect the water inlet hose from the front of your console.
2. Connect all solution pressure hoses and tools that may have water in them.
3. Start the unit and turn solution pump on. Open the tool valve until water pressure drops and water stops flowing.
4. Turn off the solution pump. Fill the water box with approximately two gallons of 100% glycol base anti-freeze.
5. Turn the solution pump override switch to the override position and start the unit. Turn the solution pump switch ON.
6. Open the tool valve until anti-freeze begins to come out of the tool. Recover ALL anti-freeze that comes out of the tools into an approved container. We strongly recommend that you re-cycle and re-use the anti-freeze.

Repeat this procedure with all the remaining tools. After all tools and pressure hoses have been filled with anti-freeze, disconnect and store them.

7. Turn the solution pump switch OFF. Attach the winterizing loop hose with attachment, Part #86260700, PRV NO.10-805380, to the solution outlet connection and the water inlet connection. Turn the solution pump switch ON.

Allow the unit to run for approximately 3 minutes with the winterizing loop hose attached.

8. Prime the chemical system with 50/50 anti-freeze/water mix. Insert the chemical inlet and prime discharge tubes into the anti-freeze container. Turn the chemical valve to PRIME until anti-freeze begins to flow out of the prime hose.
9. Now turn the chemical valve and flow simulator valves to the open position, making certain that the flow meter indicates flow and that all anti-freeze drains out of the chemical hose into an approved container, after 30 seconds, turn off both valves.

Removing Anti-Freeze From the Unit

1. Connect one end of the winterizing loop hose to the solution outlet connection. Place the other end of the loop hose, without the attachment, into an approved container.
2. Start the unit. Allow the anti-freeze to flow into the container until flow stops.
3. Fill the water box with fresh water and repeat step #2.
4. Connect the water inlet hose to the water inlet connection on the console. Turn the water supply on.
5. Connect all solution hoses and any tools which require purging of anti-freeze to the solution outlet connection(s).
6. Open the tool valves and drain the anti-freeze into an approved container until the flow is clear and all anti-freeze is purged from the tools and hoses.
7. Place the chemical prime hose into the approved container. Submerge the chemical inlet hose in water. Turn the chemical valve to the PRIME position until clear water comes through the prime hose, and then remove the prime hose from the container.

Turn the chemical valve to the ON (CHEMICAL) position. This will allow water to flow into the other side of the system.

Once all of the anti-freeze is removed, the unit is ready to use.

Eventually, the anti-freeze in your storage container will become diluted with water. If the anti-freeze level drops below 50% of the total, dispose of it and start with fresh 100% anti-freeze.

WARNING:

When disposing of used anti-freeze, observe local laws and regulations. Do not drain onto the ground or into storm drainage systems.

Service Schedule

Engine	Daily	Check engine oil level. *** Fill to proper level
Engine	Daily	Check coolant level in overflow bottle
Vacuum Pump	Daily	Spray water displacing lubricant in lubrication cup at front of console for 5 sec.
Water Pump	Daily	Check oil level.** Fill to proper level
Solution Inlet Tube Strainer	Daily	Check strainer for blockage, remove any debris
Vacuum Inlet Filter (In Waste Tank)	Daily	Clean filter, inspect, replace if damaged
Vacuum Hoses	Daily	Wash out with clean water
Automatic Waste Pump	Daily	Inspect and remove any debris or sediment
Chemical Filter	Daily	Inspect daily
Vacuum Pump	Weekly*	Check oil level. Fill to proper level
Water Box Float Valve	Weekly	Check for proper seating and shut-off
Water Pump Inlet Filter	Weekly*	Check for debris and clean
Battery	Weekly*	Check for proper fluid level. Fill with distilled water only
Solution Outlet Screen	Weekly*	Inspect and remove any debris or blockage
Pressure Regulator	50 hrs	Lubricate o-rings
Pressure Regulator	50 hrs	Lubricate plug behind spring
Solution Pressure Hoses	100 hrs	Inspect for damage or impending damage
Engine	100 hrs	Change engine oil***
Engine	100 hrs	Change oil filter***
Engine	100 hrs	Check fan belt tightness
Battery	100 hrs*	Clean battery terminals
Float Valve Seal	200 hrs.	Replace seal
Engine	200 hrs	Service air cleaner elements*
Engine	200 hrs	Check radiator hoses and clamp tightness
Fuel Pump	200 hrs	Check hose connections
Engine	200 hrs	Check spark plugs for carbon deposits and proper gap
Chemical Valves	200 hrs	Inspect and/or adjust packing nuts

Service Schedule

Vacuum Exhaust Heat Exchanger	500 hrs	Inspect cores and remove debris.
Water Pump	500 hrs	Change oil**
Pulley Set Screws & Hub Cap Screws, Water Pump Clutch Shaft Bolt	500 hrs	Check for proper torque valves. Re-torque, if required****
Drive Pulley	500 hrs	Inspect, clean and check for pulley groove wear****
Drive Pulley	500 hrs	Check pulley alignment****
Drive Belts	500 hrs	Inspect and clean****
Drive Belts	500 hrs	Check belt tension****
Chemical Pump & Check Valves	500 hrs	Replace diaphragm and check valves.
Vacuum Lubrication Lines	500 hrs	Check for line obstructions. Replace tubing if cracked or damaged
Engine	500 hrs	Replace in-line fuel filter on engine.
Engine	1000 hrs	Replace spark plugs.
Check Valve (Solution Outlet)	1000 hrs	Inspect, clean, and repair, if needed.
Vacuum Pump	1500 hrs	Drain, flush, and replace oil *****
Waste Tank Shut-off Float Switch	Monthly	Check for debris hindering movement
Inline Gas Filter	Yearly	Replace Inline Gas Filter
Engine	Yearly	Flush radiator and change engine coolant.
Engine	Yearly*	Replace air cleaner element.
Waste Tank Filters/Strainers	Yearly	Check for damage and blockage. Replace if needed.
Engine	2 years	Replace radiator hoses and hose clamps.
Engine	3 years	Replace ignition wires.

* Or as often as required

** Change water pump crankcase oil after the first 50 hours

***Change engine crankcase oil and filter after the first 50 hours

****Perform drive belt, pulley and hub maintenance after the first 25 hours of operation, and then again at 100 hours

*****If using AEON PD synthetic lubricant, 4500 hours or every 2 years, whichever comes first

Key Checkpoints

Note: Initiation of a planned preventative maintenance program will assure that your unit has optimum performance, a long operating life, and a minimal amount of "down" time.

Engine Coolant System (Radiator) Maintenance

Your engine radiator coolant system is an important part of the power plant operation. In addition, the heat exchange system which is used to provide heat for cleaning operations, is also highly dependent on the engine coolant system. Follow the recommended coolant system maintenance in the Maintenance Schedule in this manual and your Kohler engine owner's manual. Refer any additional questions to your dealer.

External Fuel Pump Maintenance

The power plant for the unit receives fuel from the main gas tank of your van/truck. An external fuel pump that provides this fuel is located on the underside of the van/truck. Loose fittings and hose connections will cause your unit to perform poorly. Follow the recommended fuel pump maintenance in the Maintenance Schedule in this manual. Refer any additional questions to your dealer.

Chemical Supply System Maintenance

The chemical supply system pulls chemicals from your chemical bottle utilizing a pump that works off the water pump pulsing. Any clogged filters or loose connections will result in a chemical supply system malfunction or a malfunction at the cleaning tool. Maintenance of the solution outlet check valve and screen are vital to effective cleaning operation and minimal unit downtime. Additionally, the hoses related to supplying water and chemical to the outlet manifold are under high pressures and experience thermal expansion and contraction. Periodic inspections of these hoses for tears, cracks, and failing connectors are necessary to avoid unwanted leaks. To keep your chemical system functioning properly, follow the chemical pump and solution outlet maintenance in the Maintenance Schedule in this manual. Refer any additional questions to your dealer.

Heat Exchanger System Maintenance

The heat exchange system in your unit transfers energy between the unwanted heat of the power plant and the solution supply system of the unit. The heat transfer of this system is highly dependent on the surface area contact in the heat exchanger cores located in the heat exchanger box. This surface area amount is adversely minimized when the supplied water is not softened to recommended levels. Hard water will result in scaling on the inside walls of the heat exchanger tubes. It is recommended that you use a dealer approved water softener to avoid premature heat exchanger core failure. Contact your dealer for advice on the water hardness levels in your area.

Additionally, the heat exchanger tubes are very sensitive to freezing conditions. As the water freezes during cold conditions, it expands in the heat exchanger tubes and causes damage. Often the tubes are cracked and require the replacement of the heat exchanger core. Refer to the Freeze Protection instructions section in this manual. Refer any additional questions to your dealer.

Vacuum Pump Maintenance

(Refer to manufacturer's manual (P/N 86269820, PRV NO. 980129) for specific maintenance instructions)

The total function of the unit is based around the performance of the vacuum pump. Heat transfer used to raise the temperature of the solution is gained from the air drawn by the vacuum pump and solution is removed from the carpet with the vacuum suction of the vacuum pump. General maintenance actions for the vacuum pump as listed in this manual are vital to prolonged vacuum pump operations. Daily lubrication of the pump is required to avoid seizure of the system. Also, waste tank filters and strainers must be maintained to prevent unwanted debris from entering the vacuum pump.

⚠ WARNING:

DO NOT service this unit while it is running. The high-speed mechanical parts as well as high temperature components may result in severe injury, severed limbs, or fatality.

NOTE: Use the hour meter as a guide for coordinating the maintenance schedule.

Engine

(Refer to manufacturer's manual (P/N 86269810, PRV NO. 980128) for specific maintenance instructions)

1. Check the engine oil level daily, when in use. Make certain that proper oil level is maintained. **NEVER** overfill.
2. Change the break-in oil after the first 50 hours of operation. Thereafter, change oil every 100 hours of operation. **USE ONLY KOHLER BRAND OIL FILTERS (PN 34412). USING ANY OTHER TYPE OIL FILTER WILL VOID YOUR ENGINE WARRANTY.**

Oil Recommendation. See "ENGINE OIL REQUIREMENTS" in Operations section.

NOTE: Using less than service class SF or SG oil or extending oil change intervals longer than recommended can cause engine damage.

3. Re-torque the manifold and exhaust tube nuts, cylinder head bolts, and carburetor attaching nuts after the **first 200 hours** of use.
4. Check the spark plugs every **200 hours**. Clean if necessary. Replace the spark plugs every **1000 hours**.

NOTE: Never sandblast spark plugs. Spark plugs should be cleaned by scraping or wire brushing.

5. Clean the air cleaner element every **200 hours**. Replace the element every **2400 hours**
6. Check the engine idle RPM every **200 hours** and adjust, if necessary. **NEVER** adjust engine RPM without a tachometer. Refer to Kohler Engine Operation and Service Manual.
7. Check the coolant level in the radiator overflow container **daily**. If no coolant is seen, remove the cap and add coolant. Change the coolant with a 50:50 coolant to water ratio every **1000 hours**. 50:50 mixture guards against corrosion.
8. Replace the in-line gas filter **yearly**.

NOTE: For additional engine service information, obtain a "Kohler Repair Manual" from any authorized Kohler Service Center. If service or repair is required, contact an authorized Kohler Service Center. You will need to provide the serial number of the engine.

Vacuum Pump

Refer to the Vacuum Pump Operation and Service Manual (P/N 86269820, PRV NO. 980129) for specific instructions.

Lubrication: We recommend that you use AEON PD Synthetic Blower Lubricant in both ends of the vacuum pump for all operating temperatures. AEON PD is formulated especially for positive displacement blower service to provide maximum blower protection at any temperature. One filling of AEON PD will last many times longer than a premium mineral oil.

NOTE: AEON PD (Part# 86189090 PRV NO. 05-008039) is the oil which PROCHEM puts in the vacuum pump at the factory. Topping off or adding petroleum oil to synthetic oil is NOT recommended.

1. Check the oil level daily to assure the proper level. PROPER LEVEL cannot be overemphasized. Too little oil will ruin bearings and gears. Too much oil will cause overheating. Use the illustration as a guide when adding oil.
2. To prevent rust from building up inside the vacuum pump (if moisture exists) we have provided a lubrication cup on the front of the unit.

First run the unit at least 1 minute to remove any moisture from the vacuum pump. Next, fill the lubrication cup with water displacing lubricant, for 5 seconds while the unit is running and the vacuum inlets are sealed. Do this at the end of each working day.

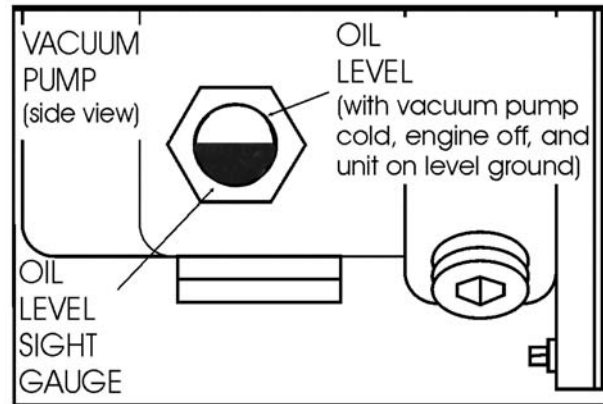

3. Drain, flush and replace oil every 1500 hours or yearly, whichever comes first. Change oil more frequently if inspection so indicates. With AEON PD synthetic lubricant, perform the oil change maintenance every 4500 hours or every 2 years, whichever comes first.
4. Vacuum pump lubrication is vital to performance of the pump. Failure to follow the maintenance schedule can lead to permanent damage to your blower.

Water Pump

Refer to the Water Pump Operation and Service Manual for specific instructions (P/N 86269900, PRV NO. 67-945621).

1. Check the crankcase oil level daily to assure the proper level. Use the illustration as a guide when checking the oil level. If the level has dropped, check for the source of leakage and repair.
2. Use the provided dipstick. Remove red filler cap and insert dipstick. Oil level should be between marks on the dipstick or use a mirror and refer to the illustration.



3. Change the crankcase oil with Cat Pump Crankcase Oil, Part #8.618-908.0, after the first 50 hours of operation. Drain and refill the crankcase oil with Cat Pump Crankcase Oil every 500 hours thereafter.
4. Other Cat approved oil equivalents are: Mobil DTE 16, Amoco Rykow 68, and Shell Tellus T68.

! CAUTION:

Water Pump Clutch

After removing or replacing water pump clutch, make certain that bolt is re-torqued to the proper value.

Component	Torque Value	
	Inch pounds	Foot pounds
Water pump shaft bolt	300	25

Vacuum Inlet Filter (In Waste Tank)

The vacuum filter in the waste tank should be removed and cleaned daily. If this is done, the filter will last for a long period of time.

Vacuum Relief Valve

While the unit is running at full RPM, block the air flow at the vacuum inlet connection and read the vacuum gauge. If adjustment is required, shut the unit down and adjust the vacuum relief valve locking nut tension. Start your unit and read the vacuum gauge. Repeat this process until the relief valve opens at 13" Hg.

Vacuum Pump Drive Belts

To tighten the vacuum pump belts:

1. Loosen the four screws which secure the vacuum pump to the mounting bracket.
2. Turn the adjusting bolts until the proper belt tension is achieved (1/2" total deflection in the center of the belt, halfway between the pulleys).

NOTE: When adjusting belt tension, make certain that the engine shaft and vacuum pump shaft remain parallel, and the belt tension is equal throughout the belt width.

3. After adjusting, re-tighten the four screws which secure the vacuum pump to the mounting bracket. Check belt alignment with straight-edge.
4. Check for pulley groove wear, clean belts and pulley grooves, check for worn belts, proper belt tension, and pulley alignment after the first 25 hours and then again at 100 hours.
5. Check for belt ride in the groove.

Water Pump Drive Belt

To tighten the water pump belt:

1. Loosen the nuts which hold the water pump mount to base.
2. Adjust the position of the belt tension adjusting bolt until the proper belt tension is achieved. (1/2" deflection in the center of the belt, halfway between the pulleys).
3. While checking the alignment, tighten the nuts which hold the water pump mount to base.

Float Valve (Water Box)

The float valve should only be adjusted if the water box is overflowing or the water level in the box is lower than 5-1/2".

1. If the box is overflowing, remove, and check the float valve for debris or damage.

NOTE: *If the float ball has any water inside it must be replaced.*

! CAUTION:

When replacing float ball, DO NOT over-tighten, as the rod can puncture the ball. Make sure to tighten the nuts on the rod.

2. Disassemble the valve and check the piston and seat for damage, replace if needed. See the "Illustrated Parts Listing" for a parts break-down.

Waste Tank Float Valve

The float valve in the waste tank shuts the unit down once the waste tank becomes full. Debris can collect around the hinge of the float valve. Check the float valve for debris at least once a month.

Waste Tank Strainer Basket

The strainer basket located inside the waste tank should be removed and cleaned whenever it is full of debris. This should be done at the end of each job.

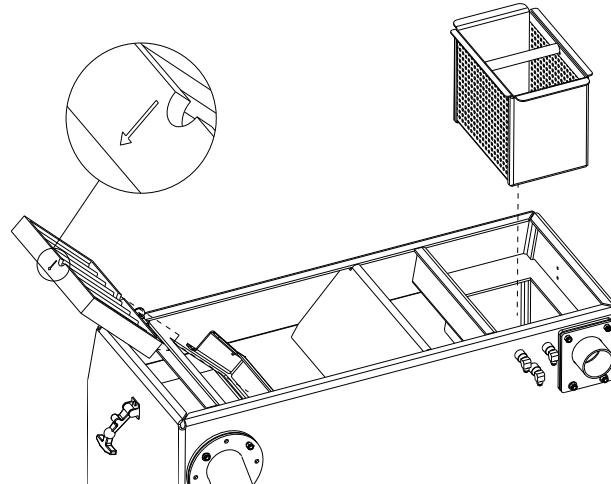

Waste Tank Vacuum Inlet Filter

The Vacuum Inlet Filter located inside the waste tank should be removed, cleaned and inspected at the beginning of each day. When replacing in tank ensure that flow indicating arrow is pointing down.

Solution Screen (Outlet)

Inspect the solution screen after the first week of running the unit by unscrewing the screen and remove any accumulated debris. Inspect the screen again at 2 and 4 weeks.

The solution screen should then be inspected every month. However, if the solution screen has a frequent build-up of debris it should be inspected and cleaned more often.

Check Valve (Outlet)

Inspect the check valve when rebuilding the chemical pump or as needed. Remove and disassemble the check valve. Check the Teflon seat for debris or abnormal wear. Clean or replace seat if needed.

NOTE: *Improper seating of the check valve poppet, damaged spring, or o-rings will cause poor operation of the chemical system.*

For the procedure, see the "General Service Adjustments" section in this manual for details.

Chemical Pump

Rebuild the chemical pump every 500 hours. This involves changing the diaphragm, disk and check valves.

For the procedure, see the "Chemical Pump" section in this manual for details.

NOTE: *Inspect chemical inlet filter on chemical jug suction hose daily.*

Chemical And Temperature Control Valves

Examine the packing nuts on all the chemical valves every 200 hours. Keeping these valve packings properly adjusted will eliminate possible leakage from the valve stems and add to overall valve life.

For the procedure, see the "General Service Adjustments" section in this manual for details.

Pressure Regulator

Lubricate the o-rings every 50 hours. Use o-ring lubricant Part #86265430, PRV NO. 05-008035.

For the procedure, see the "General Service Adjustments" section in this manual for details.

Vacuum Hoses

To assure maximum hose life, we recommend that the hoses be washed out with clean water at the end of each working day.

Solution Pressure Hoses

Inspect your solution pressure hoses for wear after the first 100 hours of use. Inspect every 25 hours thereafter. If hoses show any signs of damage or impending rupture, replace the hose.

WARNING:

DO NOT attempt to repair solution pressure hoses! Repairing solution pressure hoses may result in severe burns and serious injury!

All solution pressure hoses must be rated for 3000 PSI at 250°F. Thermoplastic hoses do not meet these specifications and should not be used. Severe burns and injury may result if the hoses do not meet these requirements.

Optional Waste Pump-Out

At the end of each work day, make certain that you remove any debris or sediment which may be inside the waste pump by pumping fresh water through the pump.

Engine Coolant Replacement

Annually the coolant in the Prochem machine should be replaced. This coolant is an integral part of the heating system and needs to be maintained as any other working part of the system. We recommend that this procedure be accomplished by the following steps.

Draining Coolant:

1. Reference Kohler Manual for specific coolant draining instructions. Drains are located at the bottom of the radiator and on the engine block next to the oil filter.

NOTE: *Be sure that used coolant is collected in a proper container and disposed of in accordance with local laws.*

2. After draining is complete, close both the radiator and helicoil petcocks.

Replacing Coolant:

1. Fill radiator with 50/50 ethelene glycol anti-freeze / water mix.
2. Start unit and set throttle to idle position.
3. As the unit warms up, maintain a full radiator with a 50/50 mix.
4. Open petcock completely on helicoil to allow any trapped air to escape. When coolant runs out of helicoil, close petcock.
5. Fill radiator with 50/50 coolant mix.
6. Re-install radiator cap.
7. Shutdown unit.

Check radiator overflow bottle. Add coolant to proper "cold" level.

General Service Adjustments

! WARNING:

USE EXTREME CAUTION The high-speed mechanical parts as well as high temperature components may result in severe injury, severed limbs, or fatality.

Engine Speed

1. This unit uses a governor to set and maintain engine speed. The engine speed is adjusted by pulling the throttle cable out to maximum travel for high speed operation. For lower temperature or vacuum setting, rotate knob clockwise two turns or as needed to obtain desired temperature and vacuum settings. Pushed in, the engine is at idle speed (1200 rpm). With throttle control pulled out, engine operates at maximum rpm (2850).

Check Valve (Solution Outlet)

Inspect the check valve whenever doing service on the chemical pump or if flow problems occur in the chemical system:

1. Remove the check valve. Be sure the small o-ring for the seat comes out with the check valve.
2. Remove the seat, using a 5/16" Allen wrench.
3. Check the Teflon seat for debris or wear. Clean or replace Teflon seat if needed.
4. Clean the poppet and spring, inspect for wear or damage, and replace as needed.
5. Re-assemble the check valve. Start the seat by hand, tighten using a 5/16" Allen wrench. DO NOT over-tighten seat.

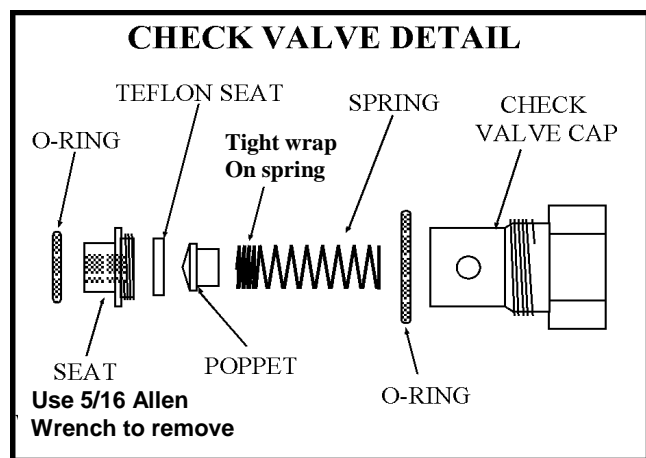

NOTE: Improper seating of the check valve poppet, damaged spring or o-rings will cause poor operation of the chemical system.

6. Lubricate the o-rings with o-ring lubricant Part #86265430, PRV NO. 05-008035 and reinstall.

Water Box

1. Check inlet strainer for debris and blockage. A blocked strainer could damage the water pump if water flow is restricted.
2. Inspect water box float valve for freedom of movement and water leaking past valve.

Chemical Pump

The only repairs which the chemical pump may require is the replacement of the diaphragm, disk or check valves. To replace the diaphragm, unscrew the cover from the body. When replacing the diaphragm, lubricate the outer edges of the diaphragm with o-ring lubricant and reassemble. To replace the check valves, unscrew the check valve caps. Replace the check valves and reassemble, using new o-rings.

DO NOT attempt to re-use o-rings once the check valves have been removed. See the "Illustrated Parts Listing" for a parts break-down on the chemical pump.

Drive Belts For Water Pump and Vacuum Pump

Use only exact replacement for system drive belts. Use only exact manufacturer and models for replacements

! CAUTION:

Make certain that when you re-torque these screws, that you use a clockwise pattern and continue until proper torque is achieved.

Torque Value		
Component	Inch/lbs	Foot/lbs
Rear Engine Hub	300	25
Vacuum Pump Hub	300	25
Front Engine Pulley	216	18

Packing Nut Adjustments For Chemical Valves

Examine the packing nut on all chemical valves for proper tension every 200 hours. When turning the knob, there should be a small amount of resistance. If not, slightly tighten the packing nut. **DO NOT** over tighten. Keeping the valve packings properly adjusted will eliminate possible leakage from the valve stem and add to overall valve life.

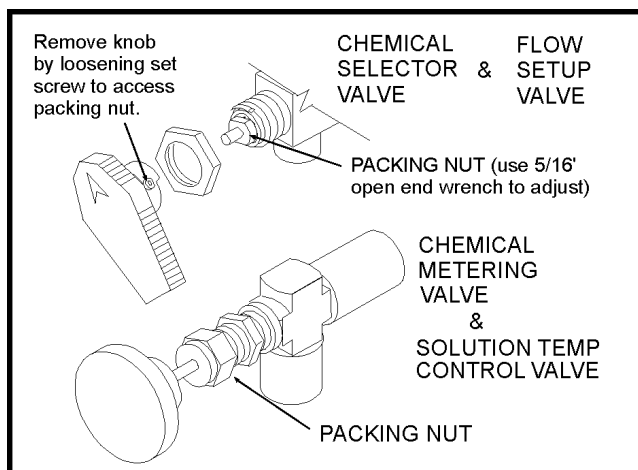

Pressure Regulator

The pressure regulator serves to maintain water pressure at a preset point and to bypass water back to the water box.

To adjust:

1. With your unit running, close the cleaning tool valve. Check the pressure gauge. Open the tool valve. We recommend setting the pressure regulator so that the pressure gauge reads 450 PSI with the tool valve open.

When the tool valve is opened, there is an approximate drop of 50 PSI in pressure. If there is a pressure drop greater than 100 PSI, it may be necessary to lubricate the o-ring in the pressure regulator.

2. If the pressure regulator requires adjustment, loosen the locking nut, then turn the adjusting body (cap) (while observing the pressure gauge on the control panel) until the desired pressure is obtained. Retighten the locking nut.

⚠ WARNING:

DO NOT loosen the adjusting body (cap) all the way (counterclockwise) or remove it while the unit is running.

We recommend that you lubricate the pressure regulator o-ring every 50 hours, or whenever required. If you do not, the stem may become seized due to inadequate lubrication. If this occurs:

- a. Shutdown the unit.
- b. Relieve all pressure from the water system.
- c. Remove the cap from the pressure regulator and remove the stem with long nose pliers.
- d. Clean and lubricate stem.
- e. Reassemble pressure regulator.

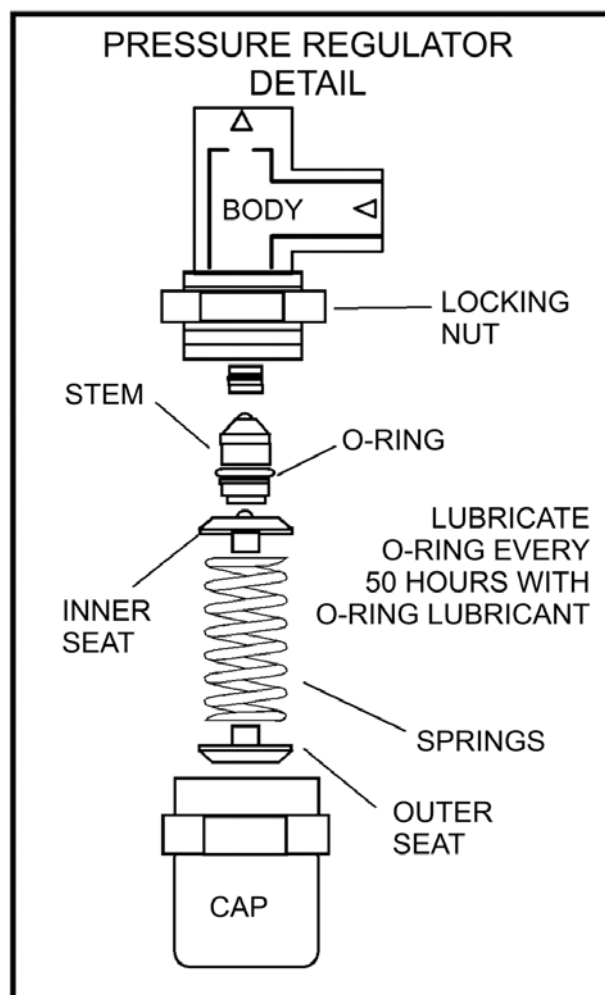

Troubleshooting

PROBLEM	CAUSE	SOLUTION
Loss of solution pump pressure. With the cleaning tool open, the solution pressure gauge reads below the normal operating pressure.	Water supply is turned off or the float valve is stuck or improperly adjusted.	Turn the water supply on or up. Check for kinks in the water supply hose. Examine the float valve and adjust or replace.
	Solution pump inlet supply line is plugged or drawing air.	Examine the water inlet filter inside the water box. Remove accumulated debris and replace if required. Check for suction leaks and loose clamps or fittings. Tighten any loose fittings or clamps. Replace any ruptured hose(s).
	Improper engine speed	Using a tachometer, check the engine speed. Full throttle engine speed is 2850 RPM. Idle engine speed is 1200 RPM. Refer to the "engine speed" section for instructions on how to re-adjust.
	Pressure regulator o-rings are dry.	Lubricate o-rings, using o-ring lubricant Part #86265430, PRV NO. 05-008035.
	Pressure regulator has worn o-rings	Check o-rings. If necessary, replace.
	Pressure regulator is dirty, stuck open, or improperly adjusted.	Clean or repair regulator. Adjust to working pressure. Lubricate o-rings, using o-ring lubricant Part #86265430, PRV NO. 05-008035.
	Low pump volume. (Measure the amount of water being returned to the water box from the pressure regulator. It should fill a gallon container about every 17 seconds).	Examine the check valves, plunger cups, and cylinder head on the water pump. Repair, whenever required (refer to the water pump service manual).
	Defective solution pressure gauge.	Replace gauge
	Orifice (spray nozzle) in the cleaning tool is worn, defective, or wrong size.	Replace Nozzle or change nozzle size.
	Debris clogging water lines or water inlet disconnect.	Clean or replace as needed.
	Belt loose or broken	Re-tension or replace as needed.
Loss of pump prime	Manually prime solution pump.	
Loss of solution volume at cleaning tool orifice. Solution gauge reads normal.	Plugged orifice and/or screen in the cleaning tool.	Unplug or replace orifice and/or screen
	Internal block between the pressure regulator manifold and the solution screen; or the solution screen is clogged	Inspect all lines, remove accumulated debris which is blocking proper flow. Replace any defective hoses. Remove, inspect, and clean the solution screen. De-scale unit and install a water softener, if necessary.
	Outlet check valve is plugged	Examine the check valve, remove any debris
	Defective quick-connect on one or more of the solution pressure hoses.	Replace defective quick-connect(s) on solution pressure hose(s).
	Cleaning tool valve is malfunctioning.	Repair or replace valve.
	Hose inner lining is constricted.	Remove restriction or replace hose.

PROBLEM	CAUSE	SOLUTION
Loss of vacuum While cleaning, the vacuum is not up to specifi- cation. Engine RPM is normal.	Vacuum obstruction	Inspect hoses for obstructions.
	Vacuum gauge is giving an improper reading.	Examine the tubing between the vacuum relief valve and the vacuum gauge and remove any blockage.
	Vacuum hose(s) is damaged, causing a suction leak.	Inspect hose(s), repair or replace.
	Waste tank gaskets not sealing properly, not positioned properly	Inspect the gasket. Repair seal or replace Re-position lid(s).
	Plugged vacuum hose or vacuum plumbing between vacuum inlet and strainer basket.	Unplug vacuum hose or inlet plumbing.
	Waste tank filter or strainer basket is plugged.	Clean or replace filter. Clean strainer basket.
	Loose vacuum pump drive belts.	Tighten the drive belts
	Waste tank drain valve is damaged or left open, causing a vacuum leak.	Drain the waste tank. Close drain valve, if open. Remove the dump valve and, after inspecting, replace the defective components.
	Vacuum relief valve requires adjustment or has a vacuum leak due to damaged diaphragm.	Re-adjust the vacuum relief valve. If the vacuum does not increase, remove and inspect the relief valve diaphragm. If damaged, replace
	Vacuum exhaust heat exchangers are plugged with lint.	Remove and clean.
Excessive Vacuum	Vacuum pump is worn out.	Replace the vacuum pump.
	Improper throttle adjustment.	Adjust throttle to set desired vacuum pressure.
Loss of chemical with the cleaning tool valve open, no chemical	Vacuum relief valve requires adjustment.	Readjust the vacuum relief valve.
	Chemical pump is improperly primed.	Refer to chemical pump priming instructions.
	Air leak in chemical supply line, priming valve or metering valve.	Check for air leaks. Replace faulty parts.
	The strainer at the inlet end of the chemical inlet line is clogged	Unclog the strainer. If damaged, replace.
	Suction leak in the inlet line leading into the chemical pump.	Inspect inlet lines and flow meter for air leaks or damage and replace, if required.
	Chemical pump check valve(s) is clogged	Remove any debris from the chemical check valve(s). Replace chemical check valve(s) or seals, if necessary.
	Chemical prime/on-off valve or chemical metering valve is defective.	Replace valve(s).
	Chemical pump diaphragm is ruptured.	Disassemble the chemical pump and replace the damaged diaphragm.
Defective cylinder in the solution pump.	Measure the pump volume. If the pump volume is less than normal, refer to "Loss of Pump Volume" in the Troubleshooting section in this manual.	

PROBLEM	CAUSE	SOLUTION
Chemical flow meter indicates flow with the tool valve closed	External leak in chemical piping	Tighten fittings. Re-apply thread sealant where required. If any fittings are damaged, replace.
	Outlet check valve is full of debris or damaged, not allowing it to close properly	Close the chemical valve on the instrument panel. If the flow meter does not indicate flow, remove debris or replace check valve, if necessary.
	Chemical pump diaphragm is ruptured	Close the chemical valve on the instrument panel. If the flow meter still indicates flow, replace the chemical pump diaphragm.
	Internal leak in chemical valve causing continual flow through prime tube to waste tank.	Tighten valve packing nut (see "General Service Adjustments" section in this manual). Replace valve, if necessary.
Solution pump does not engage	Solution pump circuit breaker has been tripped	Check the solution pump circuit breaker on the control panel. Press the circuit breaker reset button.
	Defective electrical connection in the console wiring or defective switch.	Examine switch, electrical connections, and wiring. Repair any defective connections. If there is power going to the switch but not going out, replace the defective switch.
	Solution pump has not been activated	Turn solution pump switch to on.
	Defective solution pump clutch. NOTE: The clutch may be manually set by inserting two 1/4-20 x 1/2 bolts. Line up the holes on the clutch and insert the bolts. To disengage the pump, remove the bolts.	If there is power in the switch, but not power at the clutch, replace the defective wire. If there is power at the clutch, replace the defective clutch.
	Loose or broken solution pump belt.	Tighten or replace belt.
Engine will not start. The engine does not turn over	Main circuit breaker on the control panel has been tripped.	After inspecting the unit to determine the cause of the tripped circuit breaker, press the reset button.
	Loose or corroded battery.	Clean, tighten, or replace the battery terminals.
	Dead battery.	Recharge or replace battery.
	Defective ignition switch.	Test ignition switch for power going into the switch. If there is power going in but NO power going out, replace the switch.
	Defective starter motor.	Test the starter motor. If necessary replace.
	Vacuum pump seized.	Refer to Gardner Denver Service & Repair Manual or dealer.
Starter turns over engine, but will not start	Waste tank is full.	Empty the waste tank.
	Engine temperature has exceeded 255°F, triggering the high temperature switch to shut the unit down.	Determine the cause of overheating before restarting the unit. See "Excessive Heating" in the "Troubleshooting" section of this manual.
	Defective fuel pump.	Replace the fuel pump.
	Loose or broken wires leading to waste tank float switch.	Repair or replace any broken electrical connections.
	Defective float switch in the waste tank.	Check switch for proper operation, replace as necessary.
	Oil pressure switch (located on engine), fuel shut-off solenoid (located on engine), high temperature switch (located on engine).	Test these components. If any are defective, replace. Consult the Kohler Engine Operation and Maintenance Manual.
	Engine is malfunctioning	Refer to Kohler Engine Operation and Maintenance Manual.

PROBLEM	CAUSE	SOLUTION
Engine stops running. While doing normal cleaning, the engine stops running	Engine is out of gasoline	Add gasoline to the fuel tank.
	Waste tank is full	Empty waste tank.
	Main or engine circuit breaker on the control panel has been tripped.	After inspecting the unit to determine the cause of the tripped circuit breaker, press the reset button.
	Engine coolant temperature has exceeded 245-255°F, triggering the high temperature switch to shut the unit down.	Determine the cause of the overheating before restarting the unit. Refer to the Kohler Engine Operation and Maintenance Manual.
	Defective fuel pump.	Replace fuel pump.
	Defective float switch inside the waste tank.	Check switch for proper operation. Replace as necessary.
	Defective 245-255°F engine coolant high-temperature shutdown switch.	Test switch. If necessary, replace.
	Oil pressure gauge on engine has shut down, due to insufficient oil pressure.	Refer to the Kohler Engine Operation and Maintenance Manual. DO NOT restart the engine until the cause is determined and corrected.
	No ignition in the engine or engine is malfunctioning.	Refer to the Kohler Engine Operation and Maintenance Manual.
Excessive heating	Flow restriction caused by hard water scaling.	Descale unit, repair or replace damaged plumbing components as necessary. Install water softener.
	Not enough water flow.	Check jet size of tool.
Heat exchanger leaks. NOTE: The heat exchanger will produce water condensation discharge at times during normal operation. DO NOT confuse this with a leak.	Engine/vacuum exhaust heat exchangers are damaged from frozen water.	Inspect heat exchangers for leaks. Visually inspect for damage. Pressure check after removing from the unit. (Maximum test pressure 1200 PSI).
Loss of temperature. The heat output of the unit is LESS than normal.	Temperature relief valve on water box is stuck open.	Clean temperature relief valve and test. Replace, if necessary.
	Engine RPM is low.	Reset engine RPM.
	Defective temperature gauge.	Test gauge and sensor. Replace failed component.
Automatic waste pump is malfunctioning or not operating normally NOTE: When replacing either the pump or float switch, use new electrical connectors and heat shrink. Inspect connection for watertight seal.	Defective waste pump float switch.	Replace float switch.
	Broken diaphragm.	Replace diaphragm.
	Weak battery.	Charge or replace battery if needed. Check charging station.
	Pump-out circuit breaker on control panel has been tripped.	After inspecting waste pump to determine the cause of the tripped circuit breaker, press the reset button.

Notes:

PARTS

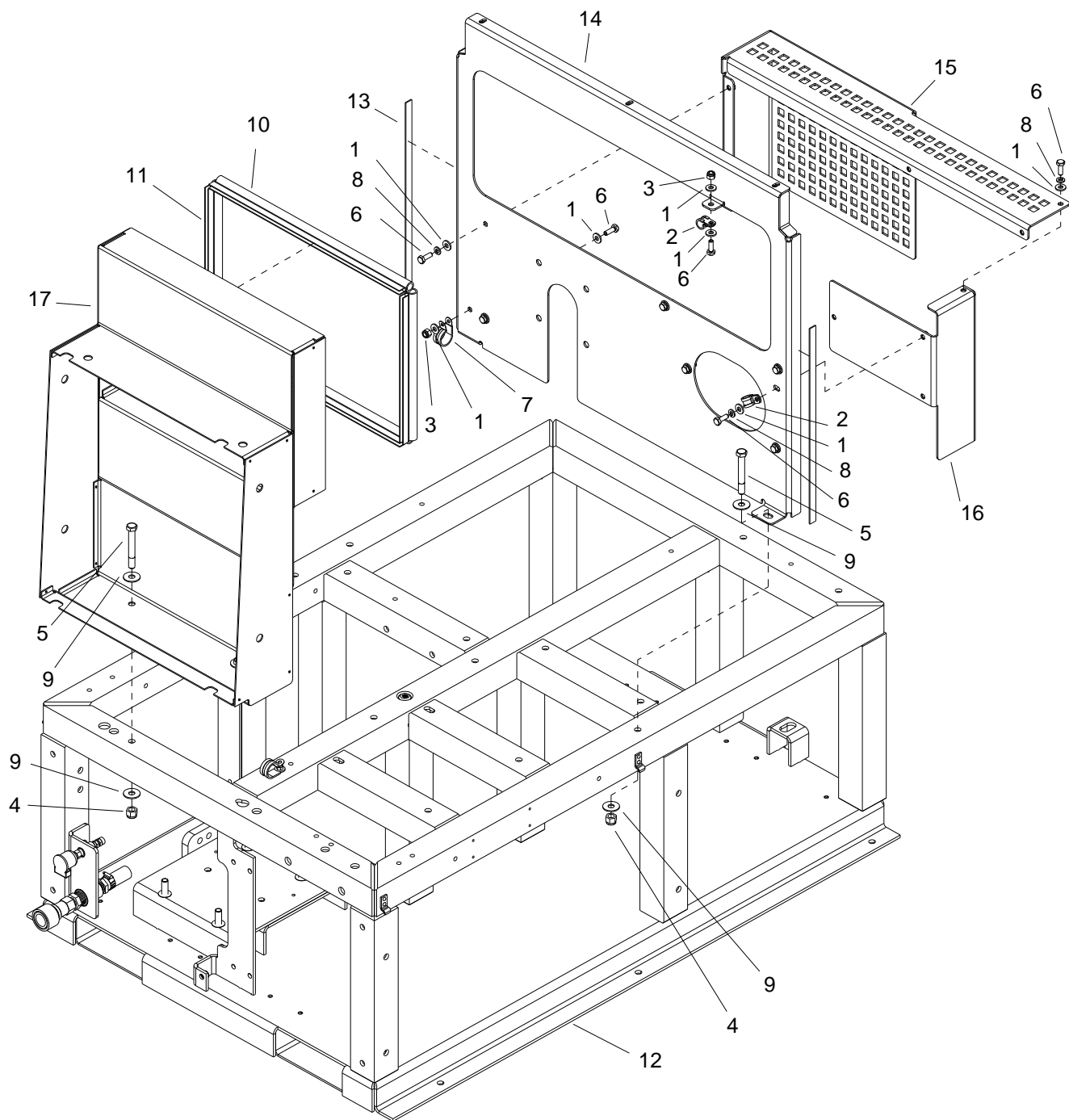

REF	PART NO.	PRV NO.	QTY	DESCRIPTION	SERIAL NO. FROM	NOTES
1	86270330	02-000066	12	FLATWASHER, 1/4		
2	86177090	03-000261	2	CLAMP, CABLE 1/2I.D. 1/4BLT		
3	86005680	57047	2	NUT, 1/4-20 HEX NYLOCK		
4	86005770	57119	4	NUT, 3/8-16 HEX NYLOCK		
5	86274000	70069	4	SCR, 3/8-16 X 3 HHCS GR5		
6	86274750	70270	10	SCR, 1/4-20 X 3/4 HHCS		
7	86233390	80887	1	CLAMP, 7/8 DIA P CUSHIONED		
8	86010780	87162	8	WASHER, 1/4 SPLIT		
9	86279510	87171	8	WASHER, 3/8 X 1 FLAT NP		
10	86282840	790634	2	TRIM,SEAL 5/8" BULB, 16		
11	86282850	790635	2	TRIM,SEAL 5/8" BULB, 10.5		
12	86043840	790793	1	ASSY, FRAME, EVRST/PEAK/ULTRA		
13	86315490	-	2	GASKET, HOOD VIBE DAMPNR		
14	86323010	-	1	BRKT, REAR ENGINE SUPT, PGT		
15	86323350	-	1	GUARD, BLWR BELT MAIN, PGT		
16	86323390	-	1	GUARD, BLWR BELT SIDE, PGT		
17	86323900	-	1	ASM, RADIATOR CLOSEOUT, PGT		

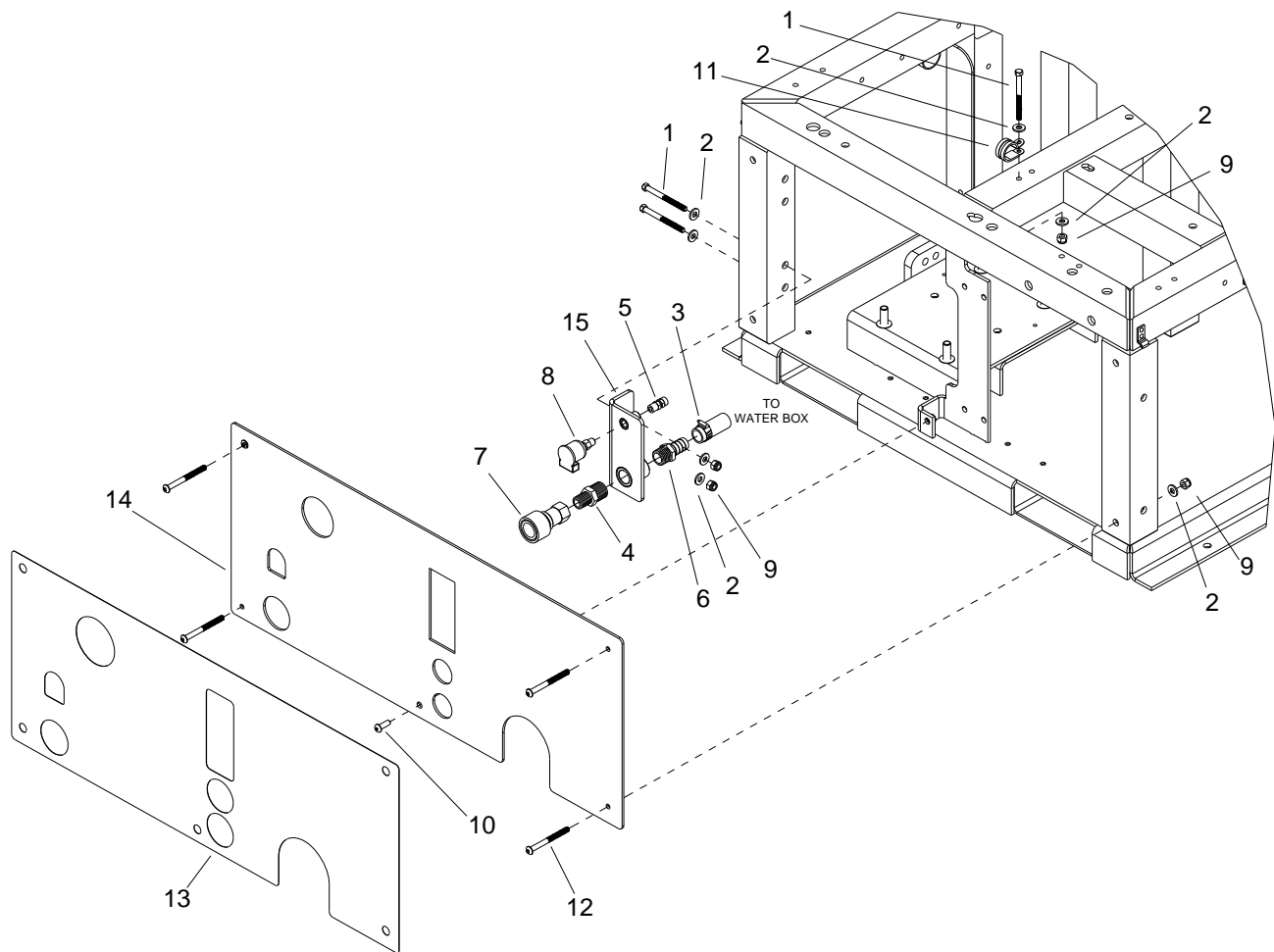

REF	PART NO.	PRV NO.	QTY	DESCRIPTION	SERIAL NO. FROM	NOTES
1	86273330	00-000286	3	SCR, CAP 1/4-20 X 2.75 HXHD		
2	86270330	02-000066	10	FLATWASHER, 1/4		
3	86177060	03-000246	1	CLAMP, HOSE, #8 SST		
4	86188210	11-800354	1	NIP, 1/2 X 3/8 HEX BR		
5	86177640	12-800059	1	CONN, 1/8P X 1/4POLY BR		
6	86181360	12-800269	1	FTTG, BRB 1/2P X 5/8H BR		
7	86179710	13-806008	1	DSC, 3/8F X 3/8FP		
8	86178700	19-800075	1	CUP, OIL FILL 1/8P		
9	86005680	57047	7	NUT, 1/4-20 HEX NYLOCK		
10	86275460	70481	1	SCR, 1/4-20 X 3/4 BHCS		
11	86233390	80887	1	CLAMP, 7/8 DIA P CUSHIONED		
12	86277730	790465	4	SCR, 1/4-20X2.75 BHCS BLK		
13	86323360	-	1	LABEL, LOWER FRONT PNL, PGT		
14	86323370	-	1	PNL, LOWER FRONT, PGT		
15	86323480	-	1	BRKT, WTR INLET & LUBE CUP, PGT		

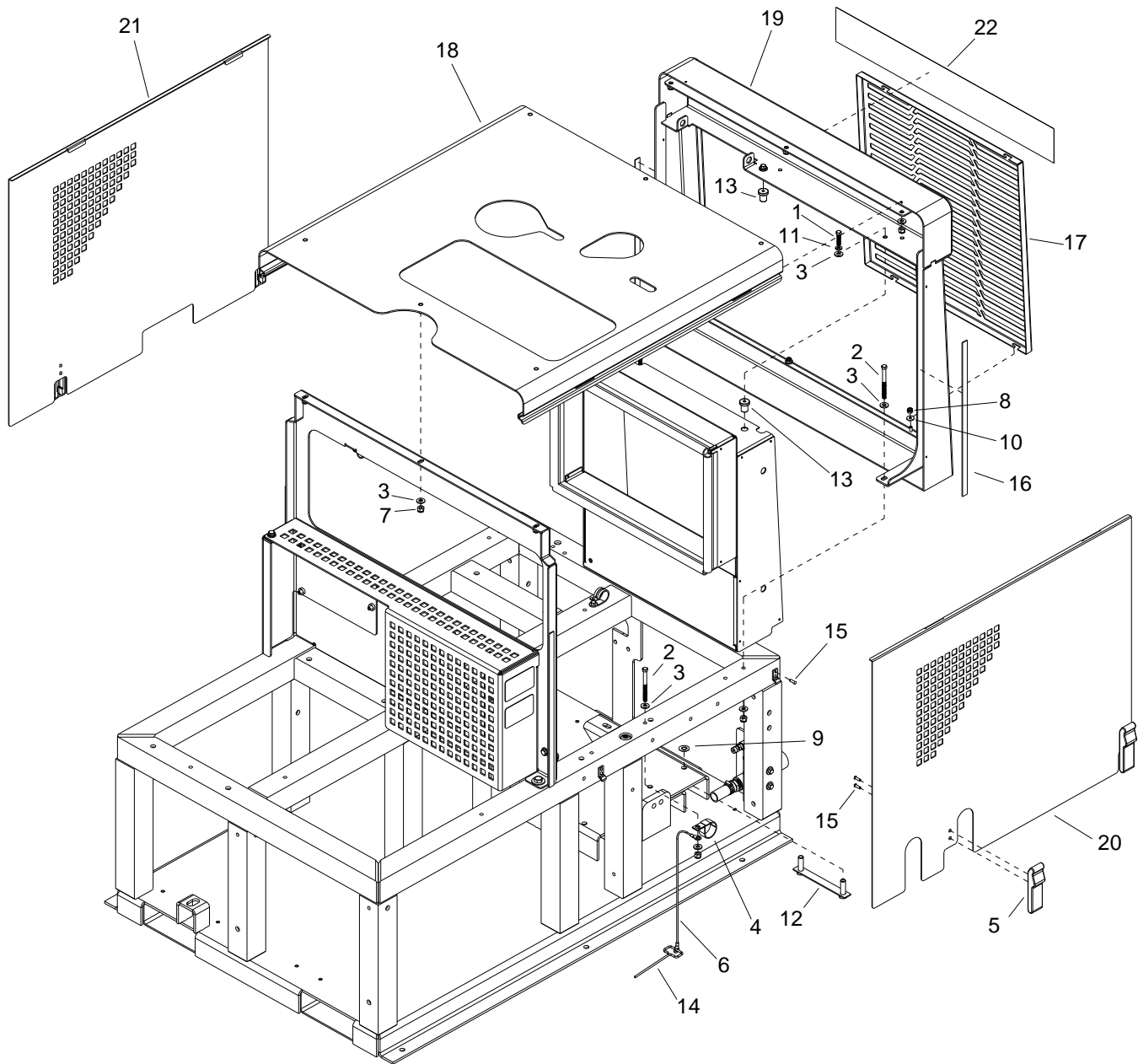

REF	PART NO.	PRV NO.	QTY	DESCRIPTION	SERIAL NO. FROM	NOTES
1	86273180	00-000078	2	SCR, 1/4-20 X 1" HXHD GRD8		
2	86273330	00-000286	3	SCR, CAP 1/4-20 X 2.75 HXHD		
3	86270330	02-000066	14	FLATWASHER, 1/4		
4	86177040	03-000149	1	CLAMP, CABLE 1-1/4 ID 5/16 BLT		
5	86161800	46-802531	4	LATCH, CONCEALED KEEPER		
6	86176170	64-950383	1	CABL, RETAIN VAC PLG 800		
7	86005680	57047	9	NUT, 1/4-20 HEX NYLOCK		
8	86270990	57090	4	NUT, 10-32 HEX NYLOCK SS		
9	86271970	57302	4	NUT, 3/8 PUSH PLATE		
10	86279340	87139	4	WASHER, 3/16 X 9/16 FLAT		
11	86010780	87162	2	WASHER, 1/4 SPLIT		
12	86057150	790436	2	STRAP, WTR PMP HOLDDOWN		
13	86189050	790464	2	NUT, WELL 1/4-20 HD		
14	86179620	790487	1	DIPSTICK, CAT PUMP OIL 5CP		
15	86191800	791414	16	RIVET, 5/32 OD X .188-.250 GL AL		
16	86315490	-	2	GASKET, HOOD VIBE DAMPNR		
17	86322980	-	1	PNL, GRILLE, PGT		
18	86322990	-	1	BRKT, CENTER HOOD, PGT		
19	86323050	-	1	ASSY, FRONT HOOD, PGT PC		
20	86325280	-	1	ASSY, LEFT HOOD, PGT		
21	86325290	-	1	ASSY, RIGHT HOOD, PGT		
22	86326000	-	1	LABEL, FRNT HD, PEAK GTX PC		

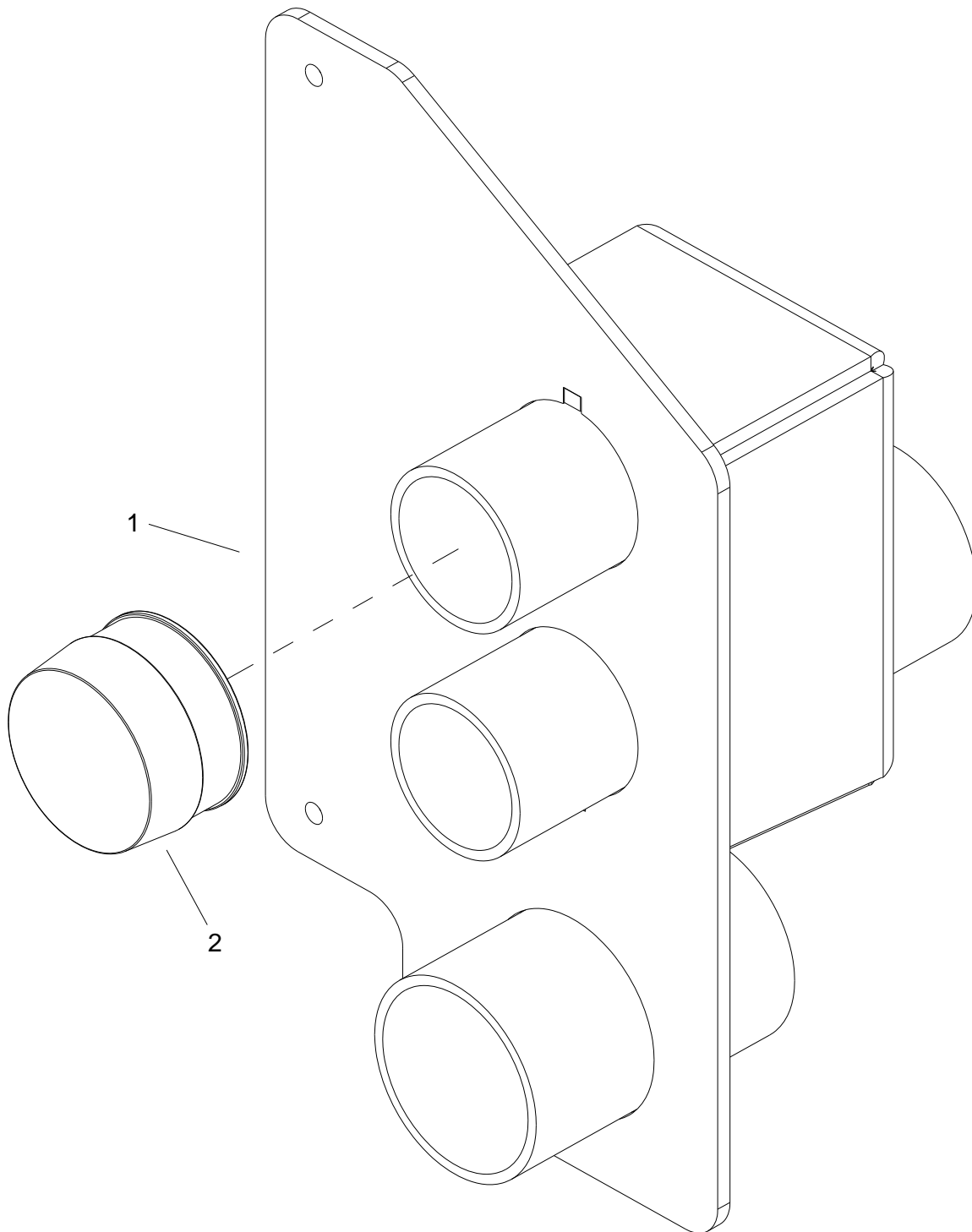

REF	PART NO.	PRV NO.	QTY	DESCRIPTION	SERIAL NO. FROM	NOTES
1	86325380	-	1	BRKT, VAC INLET, PGT		
2	86180700	32064	1	END CAP, VAC INLET, 1-1/2"		

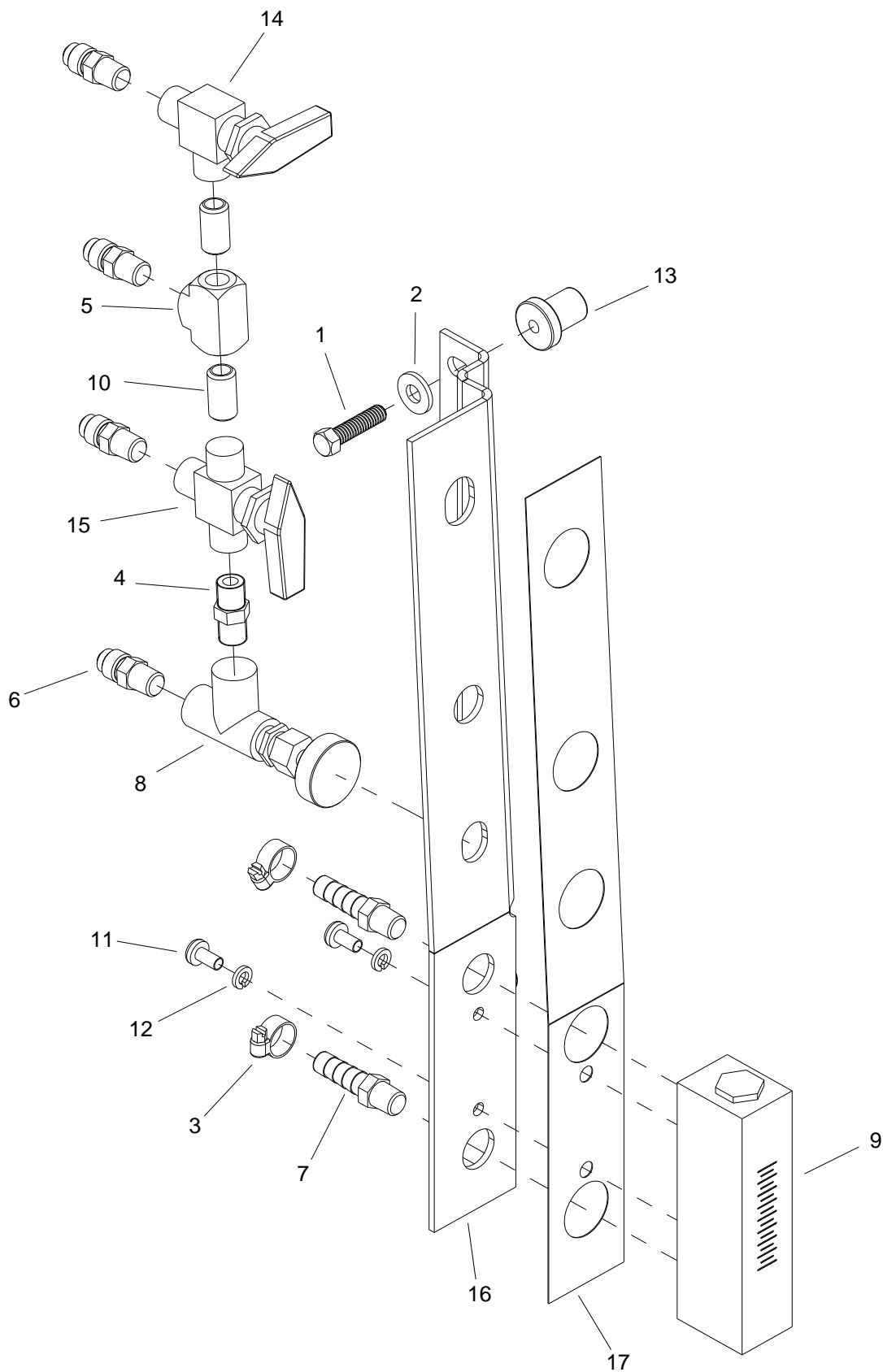

REF	PART NO.	PRV NO.	QTY	DESCRIPTION	SERIAL NO. FROM	NOTES
1	86273180	00-000078	2	SCR, 1/4-20 X 1" HXHD GRD8		
2	86270330	02-000066	2	FLATWASHER, 1/4		
3	86176990	03-000065	2	CLAMP, HOSE #4 SST		
4	86188000	11-800022	1	NIP, 1/8 HX BR		
5	86194160	11-800133	1	TEE, 1/8 BR		
6	86177660	12-800065	4	CONN, 1/8P X 1/4T		
7	86181300	12-800093	2	FTTG, BRB 1/8P X 5/16H		
8	86195050	15-808106	1	VALVE, METERING 1/8FP		
9	86181170	18-808513	1	FLOWMETER 1/8FP		
10	86247720	56032	2	NIPPLE, 1/8 CLOSE		
11	86274290	70162	2	SCR, 10-32 X 3/8 PPHMS SS		
12	86279470	87165	2	WASHER, #10 SPLIT		
13	86189050	790464	2	NUT, WELL 1/4-20 HD		
14	86195160	791339	1	VALVE, 2-WAY BALL 1/8FP		
15	86297070	-	1	VALVE, 3-WAY BALL 1/8P		
16	86324090	-	1	PNL, CHEMICAL CONTROL, PGT		
17	86324460	-	1	LBL, CHEM CNTRL PNL		

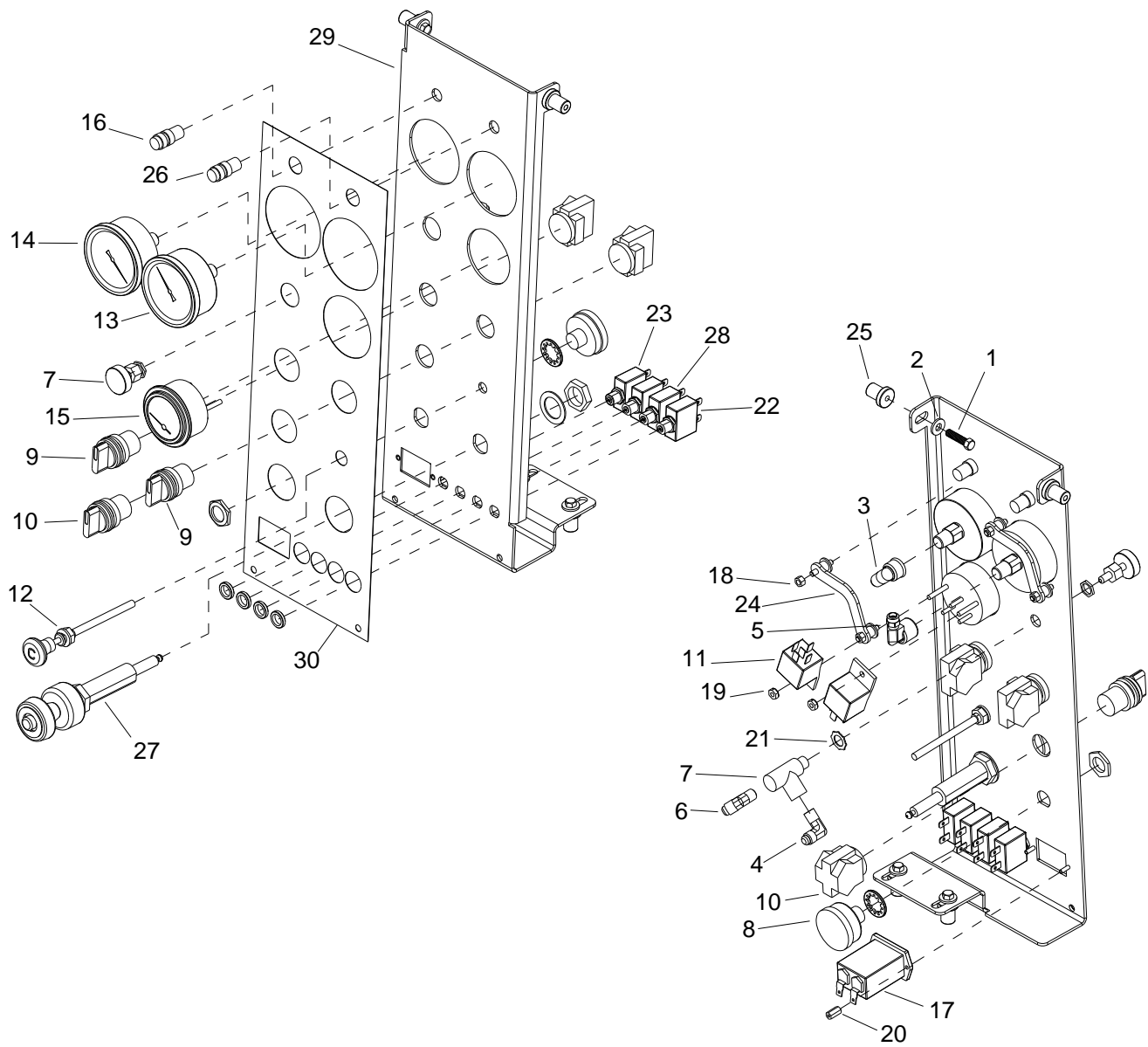

REF	PART NO.	PRV NO.	QTY	DESCRIPTION	SERIAL NO. FROM	NOTES
1	86273180	00-000078	4	SCR, 1/4-20 X 1" HXHD GRD8		
2	86270330	02-000066	4	FLATWASHER, 1/4		
3	86180350	12-800035	1	ELL, 1/4FP X 1/4T BR		
4	86180360	12-800040	1	ELL, 1/8P X 1/4T BR		
5	86180380	12-800101	1	ELL, 1/4FPx1/4POLY BR		
6	86180420	12-800261	1	ELL, 1/8P X 1/4T 45 DEG		
7	86195050	15-808106	1	VALVE, METERING 1/8FP		
8	86186020	32-900174	1	KEYSWITCH		
9	86193750	32-900205	2	SW, RTRY NON-ILLUM TM		
10	86193760	32-900206	1	SW,RTRY W/BYPASS NON-ILL		
11	86191740	35-900188	2	RELAY, ENG SHTDWN		
12	86176120	49-802518	1	CABLE, CHOKE		
13	86181930	36225	1	GAUGE, 0-1500 PSI		
14	86181950	36227	1	GAUGE, VACUUM, 30" HG		
15	86181960	36229	1	GAUGE, TEMP, DATCON		
16	86186930	51387	1	LIGHT, WARNING, IDEC AP2M		
17	86246890	54092	1	METER,0-60VDC HOUR		
18	86136310	57086	4	NUT, M5 X 4.7 HEX NYLOCK		
19	86005720	57106	2	NUT, 8-32 W/STAR WASHER PLTD		
20	86255920	73811	2	STANDOFF, 6-32 X 1/2 HEX NYL		
21	86278970	87012	1	WASHER, 7/16 EXT STAR		
22	86175600	140624	2	BRKR, CIRCUIT, 15A		
23	86175620	140654	1	BRKR, CIRCUIT 25A		
24	86175680	140702	2	BRKT, WIKA MOUNTING		
25	86189050	790464	4	NUT, WELL 1/4-20 HD		
26	86186940	790787	1	LIGHT, WARNING, AMBER, IDEC		
27	86194380	791096	1	THROTTLE CABLE, PEAK		
28	86298280	-	1	BRKR, CIRCUIT, 20A		
29	86323110	-	1	PNL, CONTROL, PGT		
30	86325580	-	1	LABEL, CONTROL PANEL, PGT		

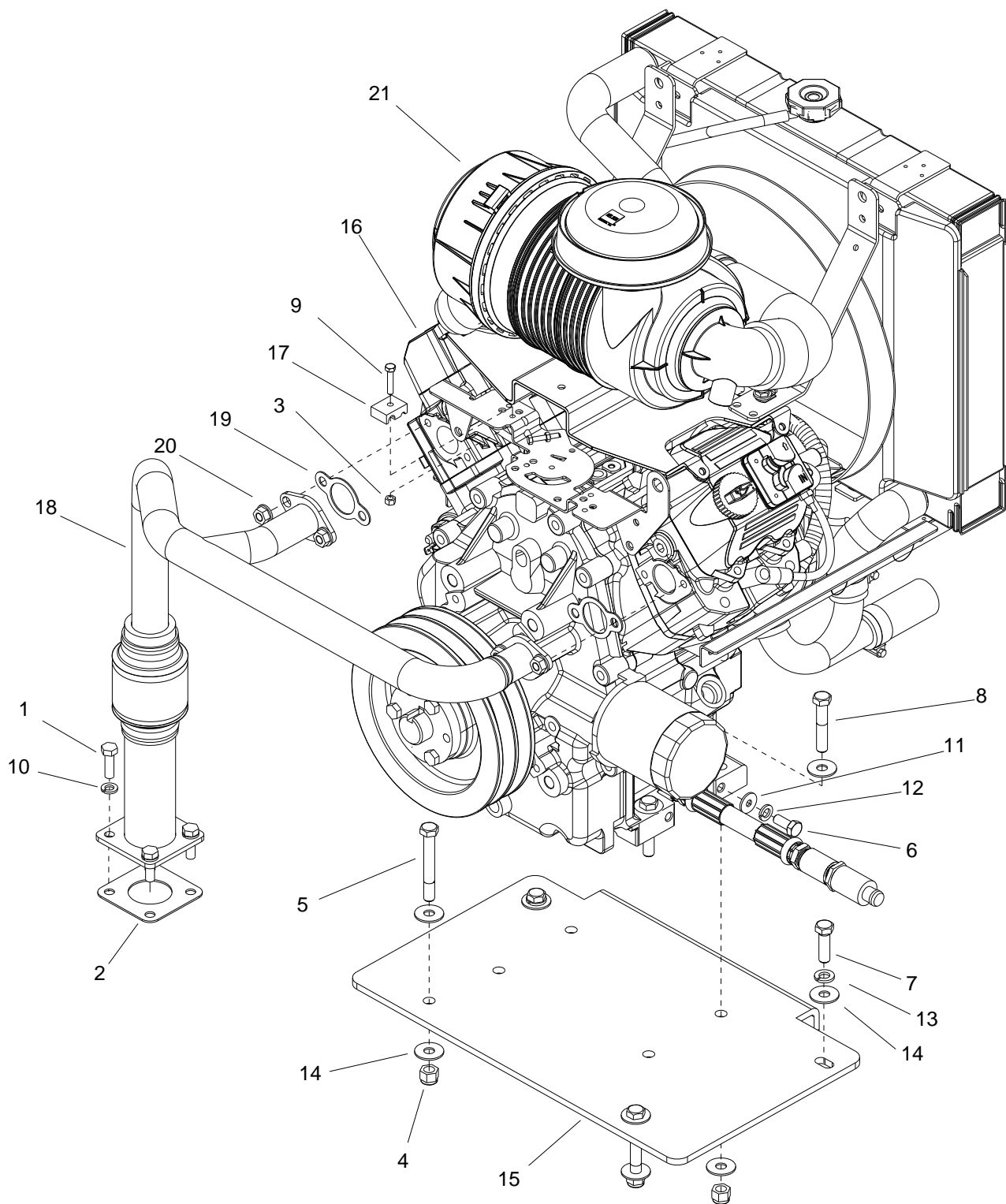

REF	PART NO.	PRV NO.	QTY	DESCRIPTION	SERIAL NO. FROM	NOTES
1	86273440	00-000340	4	SCR, MACH 5/16-18 X 1" GR8		
2	86182290	35275	1	GSKT, EXH, KUB, D902/WG972		
3	86136310	57086	1	NUT, M5 HEX		
4	86005770	57119	6	NUT, 3/8-16 HEX NYLOCK		
5	86274000	70069	2	SCR, 3/8-16 X 3 HHCS GR5		
6	86136640	70262	1	SCR, M8-1.25 X 20 HHMS PLTD		
7	86275190	70377	2	SCR, 3/8-16 X 1.25 HHCS SS		
8	86006820	70385	4	SCREW 3/8-16 X 2.0 HHCS GR5 PLT		
9	86277890	70856	1	SCR, M5 - 8 X 25MM STL, ZNC		
10	86279130	87083	4	WASHER 5/16 SPLIT LOCK PLTD		
11	86010740	87090	1	WASHER, 1/4 X 3/4 FLAT		
12	86137310	87098	1	WASHER,M8 SPLIT LOCK ZINC PLTD		
13	86010790	87163	2	WASHER, 3/8 SPLIT		
14	86279510	87171	14	WASHER, 3/8 X 1 FLAT NP		
15	86051510	790396	1	PLT, ENG MTG		
16	86180770	790532	1	ENG, 25HP KOHLER, AEGIS		
17	86177130	791083	1	CLAMP, CABLE, THROT/CHOKE		
18	86323820	-	1	TUBE, EXHAUST, KOHLER AEGIS 27HP		
19	86182730	790626	2	GSKT, EXHST, KHLR 25HP		
20	86136280	57054	4	NUT, M8 HEX		
21	86286150	34413	1	FILTER, AIR KOHLER AEGIS		PRIMARY & SECONDARY FILTER

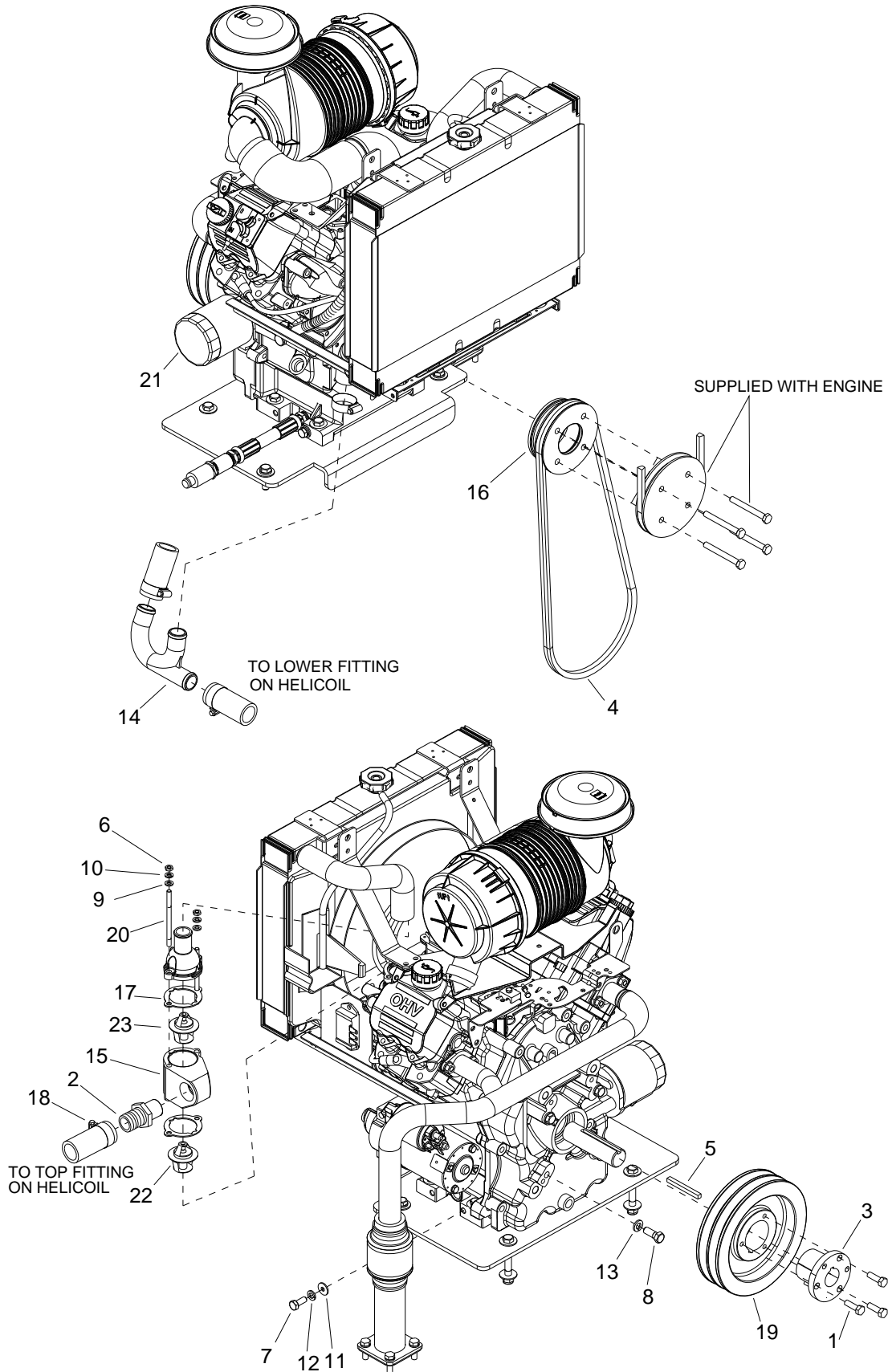

REF	PART NO.	PRV NO.	QTY	DESCRIPTION	SERIAL NO. FROM	NOTES
1	86273440	00-000340	3	SCR, MACH 5/16-18 X 1" GR8		
2	86181430	12-800367	1	FTTG, BRB 1P X 1H BR		
3	86185350	44-802214	1	HUB, P1 X 1-1/8		
4	86174950	44-802217	1	BELT, AX43 GOODYEAR MATCH		
5	86270480	48052	1	KEY, 1/4 X 1/4 X 2 1/2		
6	86136270	57053	2	NUT, M6 HEX ZINC PLATED		
7	86136640	70262	1	SCR, M8-1.25 X 20 HHMS PLTD		
8	86006740	70266	4	SCR, 3/8-16 X 1.00 HHCS GR5		
9	86279070	87056	2	WASHER, M6 FLAT		
10	86279140	87085	2	WASHER, M6 SPLIT LOCK ZINC PLTD		
11	86010740	87090	1	WASHER, 1/4 X 3/4 FLAT		
12	86137310	87098	1	WASHER, M8 SPLIT LOCK ZINC PLTD		
13	86010790	87163	4	WASHER, 3/8 SPLIT		
14	86180990	790556	1	CSTG, LOWER RAD HOSE		
15	86173560	790581	1	ADAPTER, THERMOSTAT		
16	86191260	790584	1	PULLEY, AEGIS WTR PMP		
17	86182720	790622	2	GSKT, THERM, KHLR, 25HP		
18	86177310	-	4	CLMP, HOSE #16 1-1/2 MIN 1-3/4		
19	86191050	-	1	PULL, 2TB68, 405, PWRVC2		
20	86193580	-	2	STUD, 6MM X 95MM		
21	86180940	34412	1	FILTER, OIL, KOHLER AEGIS		
22	86194360	791178	1	THERMOSTAT, 190DEG		
23	86318100	-	1	THERMOSTAT, 205 DEGREE AEGIS		
-	98407380	-	1	KIT, THERMOSTATS 190-205 AEGIS		INCLUDES 22, 23
-	86254140	791176	1	SOLENOID, KOH #25-435-05-S		
-	86181670	34417	1	FUSE 30AMP, ENG, AEGIS		
-	86192970	730343	1	SPARKPLUG, KOHLER, RC14YC		

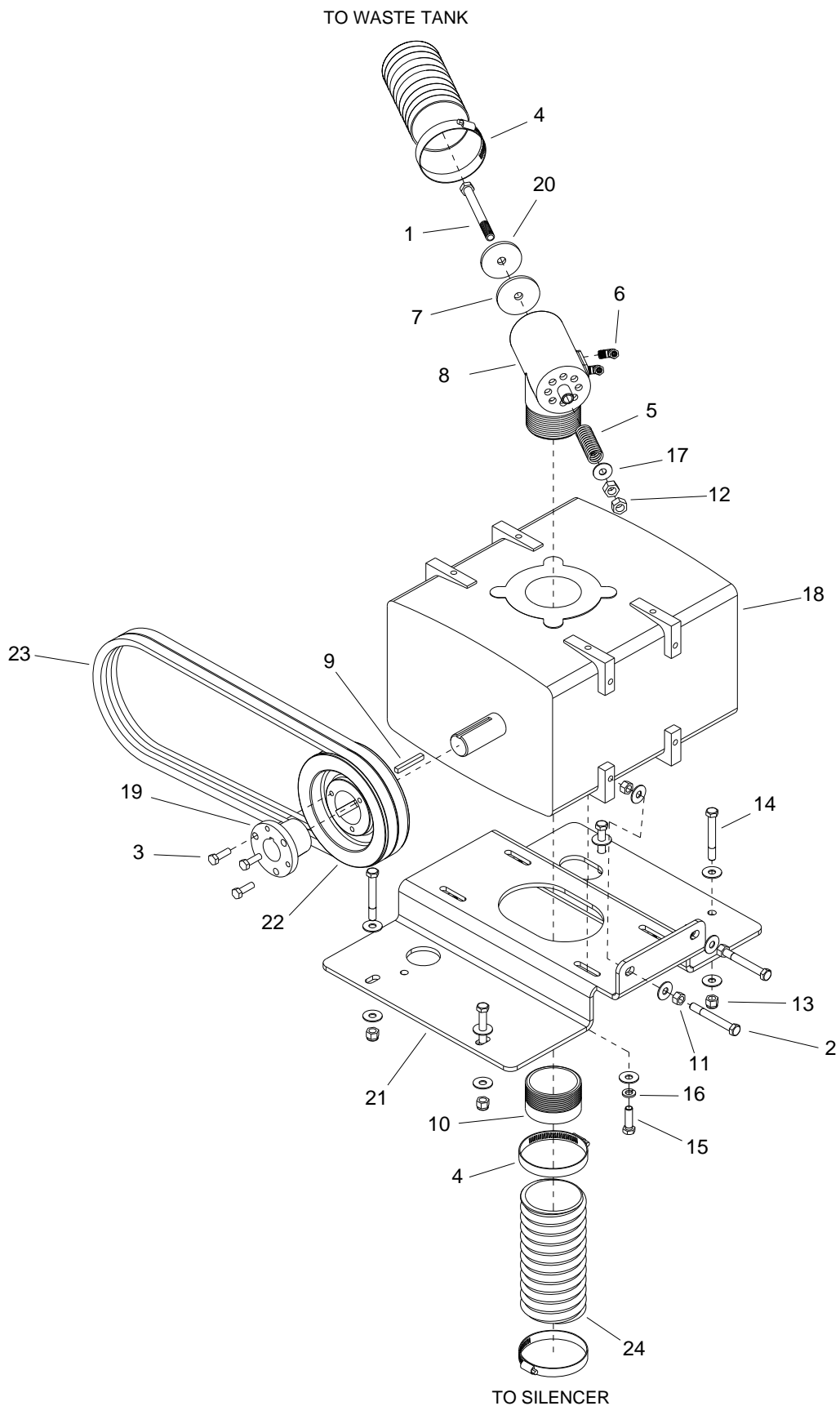

REF	PART NO.	PRV NO.	QTY	DESCRIPTION	SERIAL NO. FROM	NOTES
1	86273320	00-000284	1	SCR, CAP 7/16-14X4 HXHD		
2	86273420	00-000336	2	SCR,CAP 3/8-16X3 ALL THD		
3	86273440	00-000340	3	SCR, MACH 5/16-18 X 1" GR8		
4	86177010	03-000112	3	CLAMP, HOSE #48		
5	86193230	04-000091	1	SPRING, VAC REL VLV		
6	86180370	12-800099	2	ELL, 1/8P X 1/4 POLY BR		
7	86179580	43-807074	1	DIAPHRAM, VAC REL VLV		
8	86180600	52-501573	1	ELL, VAC REL VLV		
9	86049230	54-500412	1	KEY, 1/4 SQ X 1.88		
10	86188500	54-501593	1	NIP, VAC EXH OUTL		
11	86005730	57111	4	NUT, 3/8-16 HEX		
12	86271070	57114	2	NUT, 7/16-14 HEX		
13	86005770	57119	4	NUT, 3/8-16 HEX NYLOCK		
14	86274000	70069	4	SCR, 3/8-16 X 3 HHCS GR5		
15	86275190	70377	4	SCR, 3/8-16 X 1.25 HHCS SS		
16	86010790	87163	4	WASHER, 3/8 SPLIT		
17	86279510	87171	17	WASHER, 3/8 X 1 FLAT NP		
18	86175400	140618	1	BLWR, 3FLW, 4M, TI406		
19	86185390	790444	1	HUB, P1 X 1-1/4		
20	86311600	-	1	WASHER, VAC REL VLV, #4VAC		
21	86322920	-	1	BRKT, BLOWER MTG, PGT		
22	86323290	-	1	PULLEY, 2TB60		
23	86325510	-	2	BELT, BX47 TORQUE FLEX		
24	86325520	-	1	HOSE, BLOWER TO SILENCER		

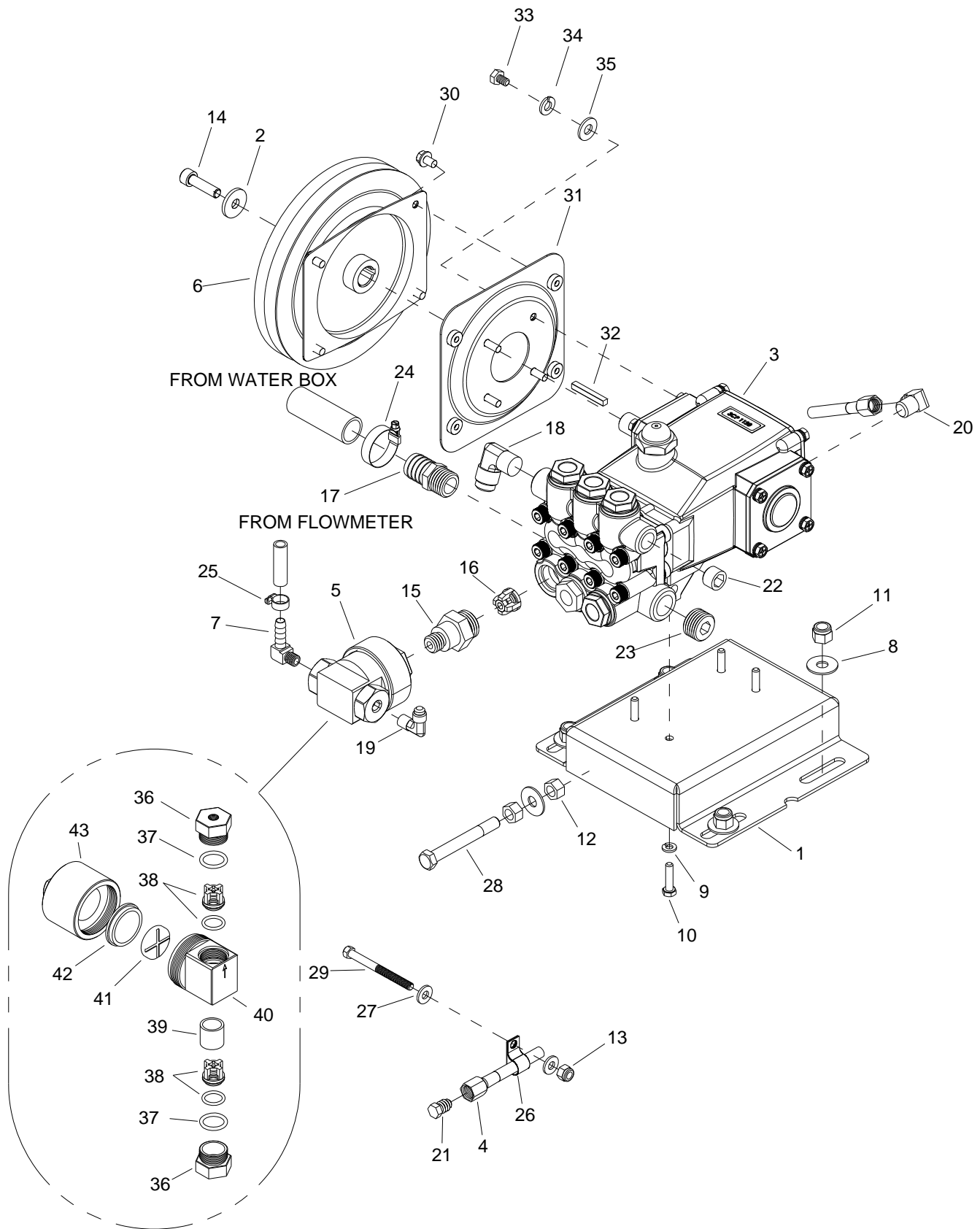

REF	PART NO.	PRV NO.	QTY	DESCRIPTION	SERIAL NO. FROM	NOTES
1	86326970	-	1	BRKT, WTR PMP MTG		
2	86279820	87240	1	WSHR, .328 ID X 1.00 OD X .119 ZNC		
3	86190760	-	1	PMP, WTR, 3CP, 3.6GPM, PEAK		INCLUDES 33, 34, 35
4	86183470	-	1	HOS, 3/16X23(1/4FT BS)MET		
5	86191440	791173	1	PUMP, CHEM, PULSE, GP		
6	86177510	790613	1	CLUTCH, ELE, WTR PMP CAT 3CP		INCLUDES 2, 14, 30, 31, 32
7	86179920	790605	1	EL, 90DEG 1/8 X 5/16HB		
8	86279510	87171	5	WASHER, 3/8 X 1 FLAT NP		
9	86279140	87085	4	WASHER, M6 SPLIT LOCK ZINC PLTD		
10	86276570	70691	4	SCR, M6 X 25 HHCS		
11	86005770	57119	4	NUT, 3/8-16 HEX NYLOCK		
12	86005730	57111	2	NUT, 3/8-16 HEX		
13	86005680	57047	1	NUT, 1/4-20 HEX NYLOCK		
14	86273700	140644	1	BLT, 5/16-18 X 1, SOC, ZNC		
15	86173750	52-809125	1	ADPT, CAT CHEM PMP		
16	86191780	52-809123	1	RETAIN, VALVE SPRING		
17	86181370	12-800278	1	FTTG, BRB 1/2P x 3/4H BR		
18	86180410	12-800225	1	ELL, 3/8P X 1/2T BR		
19	86180360	12-800040	1	ELL, 1/8P X 1/4T BR		
20	86180340	12-800031	1	ELL, 1/4P X 1/4T BR		
21	86190540	12-800029	1	PLUG, 1/4T BR		
22	86190520	11-800224	1	PLUG, 3/8 SOCHD BR		
23	86190480	11-800069	1	PLUG, 1/2 SOCHD BR		
24	86177020	03-000113	1	CLAMP, HOSE #12 SST		
25	86176990	03-000065	1	CLAMP, HOSE #4 SST		
26	86177210	03-000051	1	CLMP, CABL 7/16ID 1/4BLT		
27	86270330	02-000066	2	FLATWASHER, 1/4		
28	86273420	00-000336	1	SCR, CAP 3/8-16X3 ALL THD		
29	86273330	00-000286	1	SCR, CAP 1/4-20 X 2.75 HXHD		
30	86273710	140645	4	BLT, 1/4-20 X 3/8 SER FLNG		
31	86249610	790610	1	BRKT, CLTCH, WTR PMP, 3CP CAT		
32	86241860	48099	1	KEY, .20 X .20 X 1.45, 3CP CAT		
33	86136740	70764	4	SCREW M6 - 1 X 15 PHMS BLK		
34	86279130	87083	4	WASHER, 5/16 SPLIT LOCK PLTD		
35	86278830	02-000143	6	WASHER, 5/16 FLAT PLTD		
-	86282770	51372	1	LOOM, 1/4 HI TMP X 10"		NOT SHOWN
-	86265780	-	1	CONN, BULLET M(.156)		NOT SHOWN
36	86195120	65248	1	VALVE CAP, 303 SST, OUTPUT		
37	86189290	65249	2	O-RING, DURO, .862ID X .103CS		
38	86195110	65247	2	VALVE KIT, ASM, CHEM, PULSE PUMP		
39	86192920	65246	1	SPACER RING, 303 SST		
40	86191340	65253	1	PULSE PUMP, BODY		
41	86249220	65252	1	PLASTIC DISC		
42	86179550	42-809047	1	DIAPHRAGM, CHEM PUMP		
43	86194630	65250	1	PULSE PUMP, TOP COVER INLET		

Water Pump

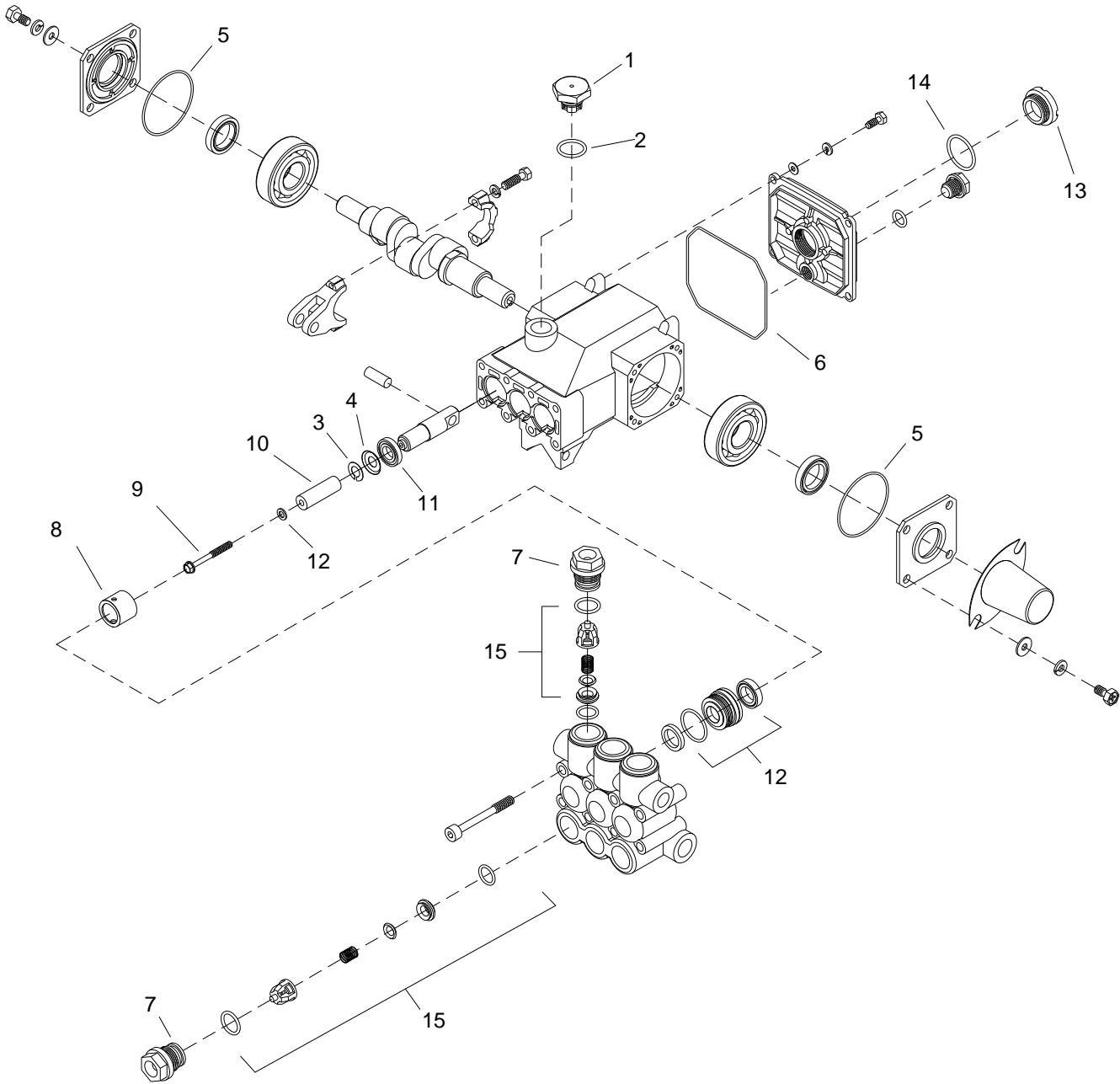

REF	PART NO.	PRV NO.	QTY	DESCRIPTION	SERIAL NO. FROM	NOTES
1	86176520	42-809238	1	CAP, OIL FILLER		
2	86189200	42-809239	1	O-RING, OIL FILL CAP		
3	86195580	42-809249	1	WASHER, KEYHOLE M18		
4	86024830	42-809381	1	SLINGER, BARRIER		
5	86189210	42-809394	2	O-RING, BEARING CVR		
6	86024780	42-809402	1	O-RING, CRANK CVR		
7	86190560	42-809404	2	PLUG, VALVE		
8	86024810	42-809405	1	RETAINER, SEAL		
9	86024820	42-809407	1	RETAINER, PNLGR W/STUD		
10	86190600	42-809408	1	PLUNGER		
11	86192260	42-809409	1	SEAL, OIL CRANKCASE		
12	86186090	42-809410	1	KIT, SEAL		ORDER 1 EACH
13	86181970	42-902380	1	GAUGE, OIL LEVEL		
14	86181800	43-807063	1	GASKET, OIL GAUGE		
15	86286260	66-950441	-	KIT, VLV CAT 3CP1140, 33258		ORDER 1 EACH TO REPLACE ALL VALVES

Vacuum / Exhaust Heat Exchanger and Silencer

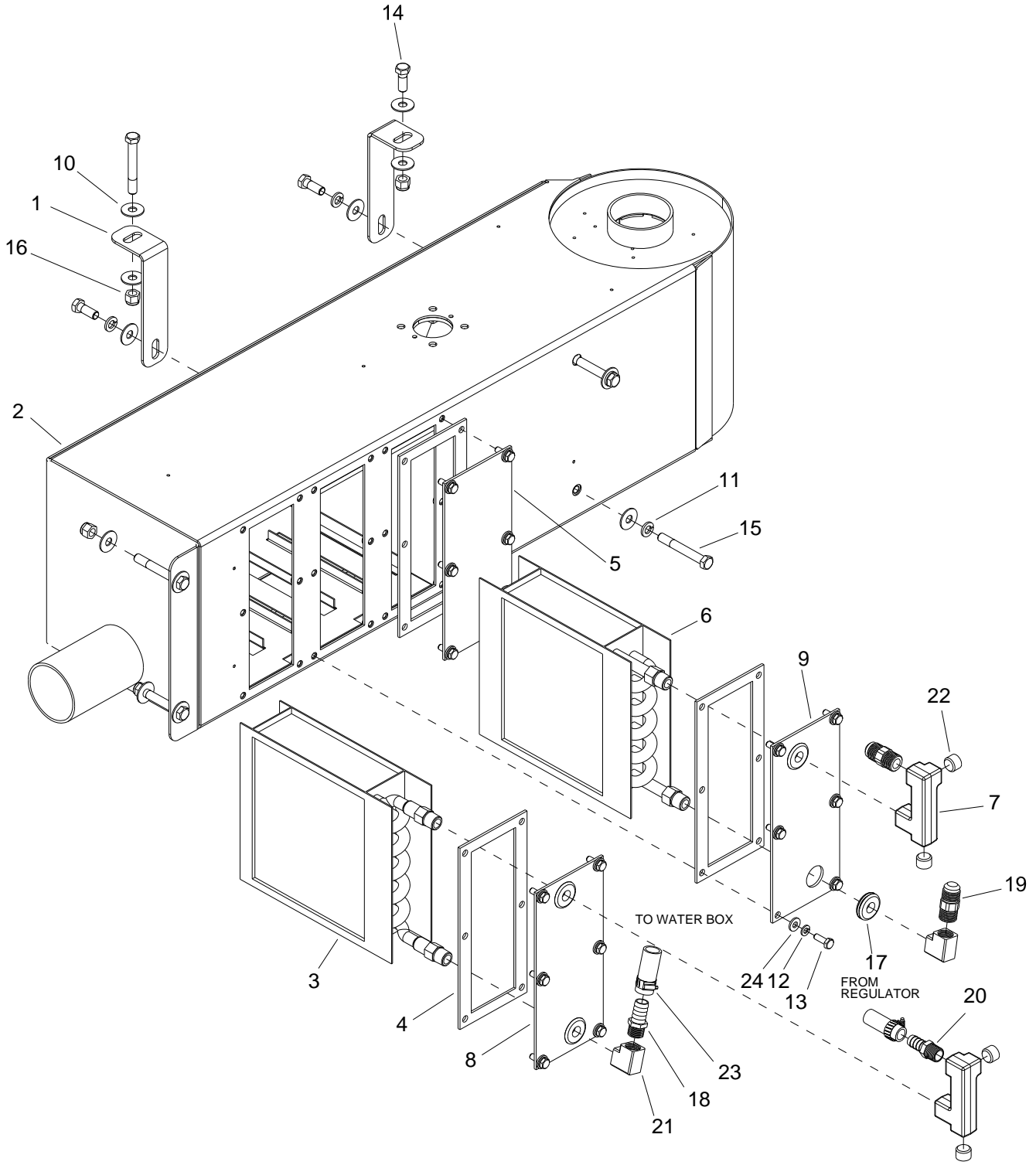

REF	PART NO.	PRV NO.	QTY	DESCRIPTION	SERIAL NO. FROM	NOTES
1	86325250	-	2	BRKT, HE BOX SUPPORT, PGT		
2	86324450	-	1	HSG, VAC HE BOX, PGT		
3	86318840	-	1	ASSY, HEATER CORE COPPER, GT		
4	86313690	-	3	GASKET, HEATER CORE COVER		
5	86051550	790578	1	PLT, COVER-VAC HE BOX		
6	86043150	790388	1	ASSEMBLY, HEATER CORE SS		
7	86187210	790038	2	MANIFOLD, HEATER CORE		
8	86051230	620024	1	PLATE, HTR CORE CVR FRT, STL		
9	86051220	620023	1	PLATE, HTR CORE CVR, STL		
10	86279510	87171	12	WASHER, 3/8 X 1 FLAT NP		
11	86010790	87163	4	WASHER, 3/8 SPLIT		
12	86010780	87162	18	WASHER, 1/4 SPLIT		
13	86274750	70270	18	SCR, 1/4-20 X 3/4 HHCS		
14	86006740	70266	3	SCR, 3/8-16 X 1.00 HHCS GR5		
15	86274000	70069	5	SCR, 3/8-16 X 3 HHCS GR5		
16	86005770	57119	4	NUT, 3/8-16 HEX NYLOCK		
17	86182190	36238	4	GROM, 1/2 ID X 1-1/8 OD		
18	86181400	12-800345	1	FTTG, BRB 3/8P x 5/8H BR		
19	86177700	12-800282	2	CONN, 3/8P X 1/2T BR		
20	86181330	12-800161	1	FTTG, BRB 3/8PX1/2H BR		
21	86180220	11-800276	2	ELL, 3/8 BR		
22	86190520	11-800224	4	PLUG, 3/8 SOCHD BR		
23	86177060	03-000246	2	CLAMP, HOSE, #8 SST		
24	86270330	02-000066	18	FLATWASHER, 1/4		

Heli-Coil Heat Exchanger

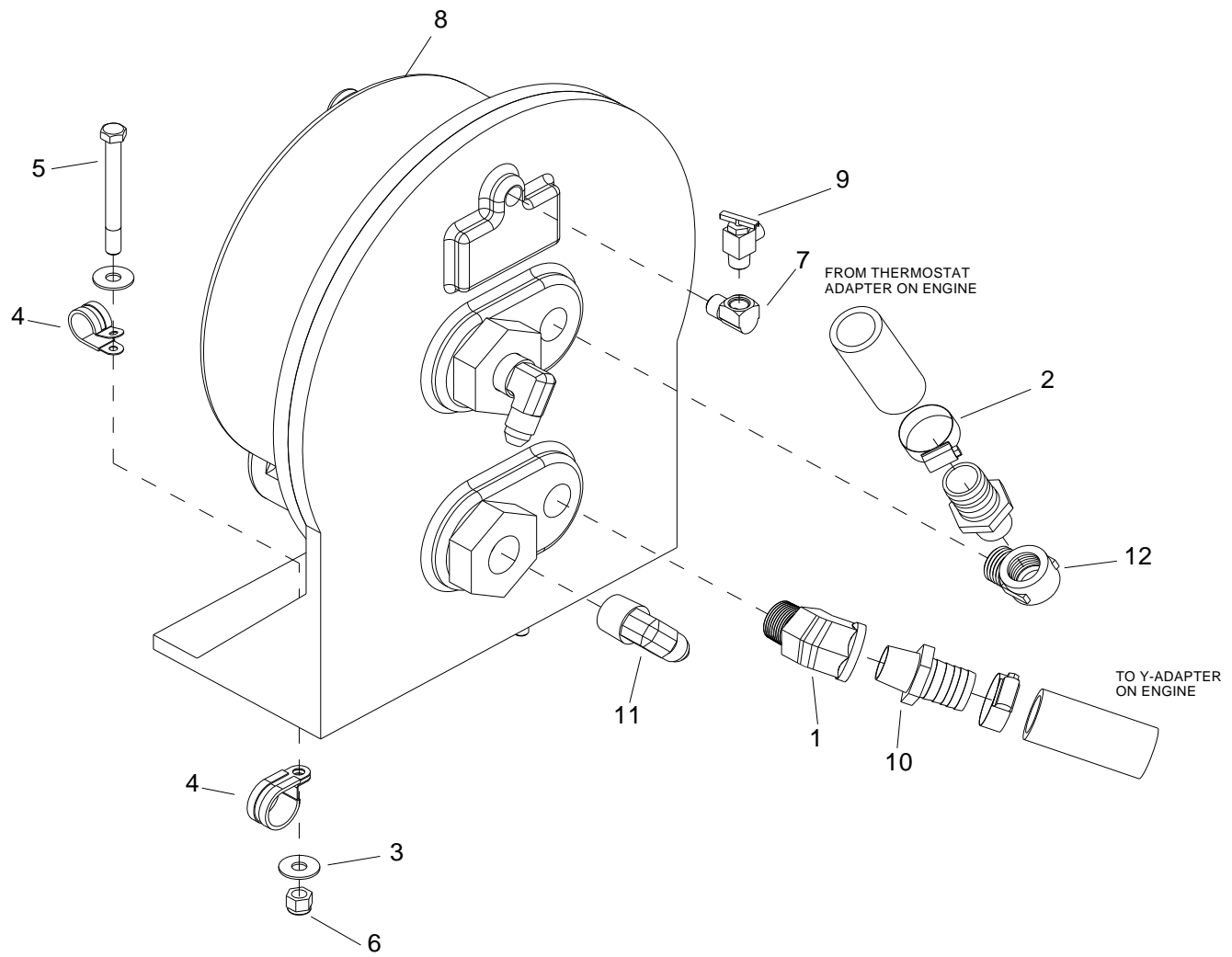

REF	PART NO.	PRV NO.	QTY	DESCRIPTION	SERIAL NO. FROM	NOTES
1	86180000	-	1	ELBOW, 3/4" 45 DEG BRASS ST		
2	86177310	-	2	CLMP, HOSE #16 1-1/2 MIN 1-3/4		
3	86279510	87171	4	WASHER, 3/8 X 1 FLAT NP		
4	86233410	81270	2	CLAMP, 3/4 DIA CUSHION .406 DIA		
5	86275860	70554	2	SCR, 3/8-16 X 3.50 HHCS GR5		
6	86005770	57119	2	NUT, 3/8-16 HEX NYLOCK		
7	86197360	31016	1	ELBOW, 1/4 NPT STREET		
8	86048290	57-520073	1	HE, HELI-COIL, PRF, BC		
9	86177560	15-808073	1	COCK, DRN 1/4PX1/4HOS ELL		
10	86181420	12-800361	2	FTTG, BRB 3/4"P x 1"H BR		
11	86180430	12-800326	2	ELL, 3/4P X 1/2T BR		
12	86180260	11-800401	1	ELL, 3/4 ST BR		

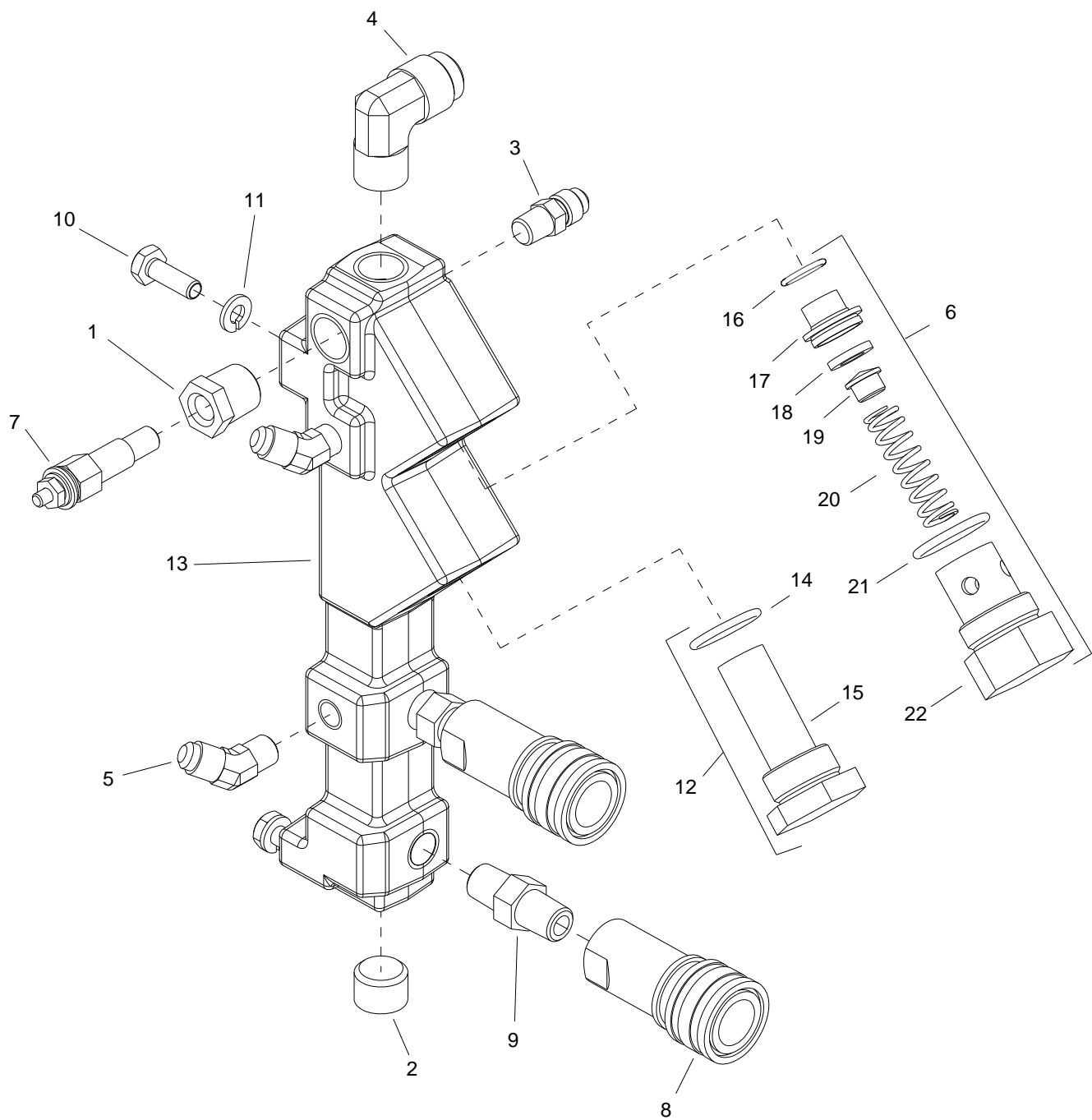

REF	PART NO.	PRV NO.	QTY	DESCRIPTION	SERIAL NO. FROM	NOTES
1	86175920	11-800118	1	BUSH, 3/8 X 1/8 BR		
2	86190520	11-800224	1	PLUG, 3/8 SOCHD BR		
3	86177660	12-800065	1	CONN, 1/8P X 1/4T		
4	86180410	12-800225	1	ELL, 3/8P X 1/2T BR		
5	86180420	12-800261	2	ELL, 1/8P X 1/4T 45 DEG		
6	86195030	15-808094	1	VALVE, CHECK		INCLUDES 16-22
7	86192490	34-903019	1	SENDER, TEMP 140-320 DEG		
8	86002450	22015	2	COUPLER, 1/4 QD		
9	86247680	56015	2	NIPPLE, 1/4 HEX		
10	86274750	70270	4	SCR, 1/4-20 X 3/4 HHCS		
11	86010780	87162	4	WASHER, 1/4 SPLIT		
12	86192240	730224	1	SCRN, MESH W/O-RING, SOL MNFLD		INCLUDES 14, 15
13	86187220	790324	1	MANIFOLD, SOLUTION		
14	86189260	43-810053	1	O-RING		
15	86192210	14-806549	1	SCREEN, CHECK VALVE		
16	86189230	43-810008	1	O-RING		
17	86192390	16-808223	1	SEAT, CHK VLV ASSY		
18	86194250	16-808225	1	TEFLON SEAT		
19	86190910	16-808226	1	POPPET, CHK VLV ASSY		
20	86193260	16-808224	1	SPRING		
21	86189270	43-810079	1	O-RING, 7/8 ID 1-1/16 OD		
22	86176350	16-808222	1	CAP		

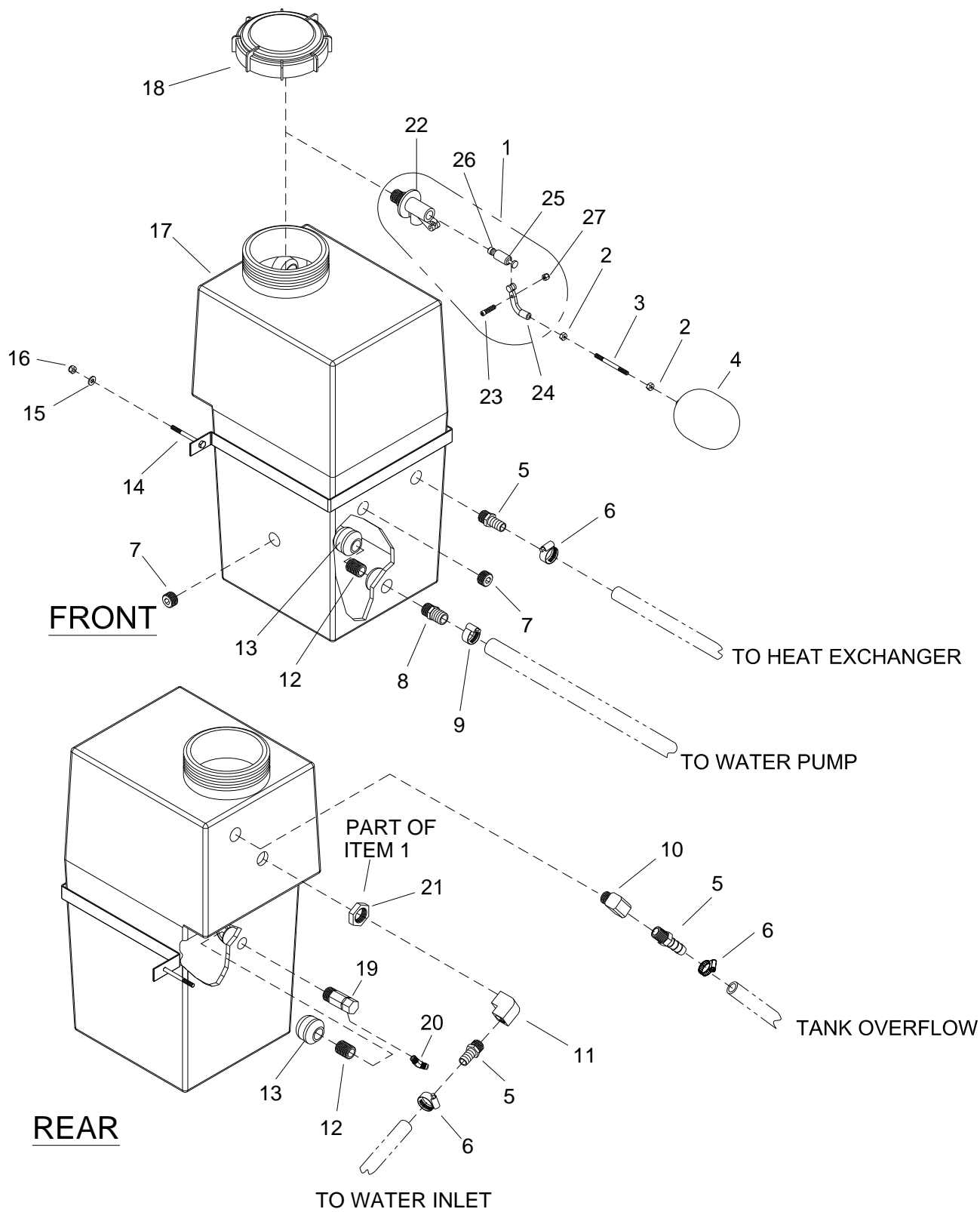

REF	PART NO.	PRV NO.	QTY	DESCRIPTION	SERIAL NO. FROM	NOTES
1	86195060	15-808110	1	VALVE, FLOAT		INCLUDES 21-27
2	86270770	57006	2	NUT, 1/4-20 HEX		
3	86056660	790411	1	ROD, FLOAT (1/4-20 X 4") SS		
4	86174540	19-807014	1	BALL, FLOAT		
5	86181360	12-800269	3	FTTG, BRB 1/2P X 5/8H BR		
6	86177060	03-000246	6	CLAMP, HOSE #8 SST		
7	86190480	11-800069	2	PLUG, 1/2 SOCHD BR		
8	86181370	12-800278	1	FTTG, BRB 1/2P X 3/4H BR		
9	86177020	03-000113	2	CLAMP, HOSE #12 SST		
10	86180570	31098	1	ELL, STREET 1/2 BR		
11	86180250	11-800361	1	ELL, 1/2 BR		
12	86188180	11-800300	1	NIP, 1/2 X CL		
13	86193440	14-806540	1	STRAINER, SUC END 1/2FP		
14	86189780	00-000268	2	SCR, CAP 1/4-20 X 2.75 HXHD		
15	86270330	02-000066	2	FLATWASHER, 1/4		
16	86005680	57047	2	NUT, 1/4-20 HEX NYLOCK		
17	86031950	75436	1	TANK, WATER BOX		
18	86046550	11-800432	1	CAP, WATER BOX		
19	86195340	15-808075	1	VLV, TEMP REL 145 DEG		
20	86180420	12-800261	1	ELL, 1/8P X 1/4 T, 45 DEG		
21	86189010	52-501706	1	NUT, FLOAT VALVE		
22	86309160	-	1	BDY, FLOAT VALVE		
23	86308950	-	1	SCR, HHSS, M5 X 20MM, SS		
24	86309140	-	1	ARM, PIVOT-FH VALVE		
25	86189870	16-808219	1	PISTON, FH VLV		
26	86192380	16-808164	1	SEAT, FLOAT VLV		
27	86024750	94028	1	NUT, M5 HEX NYLOCK SS		

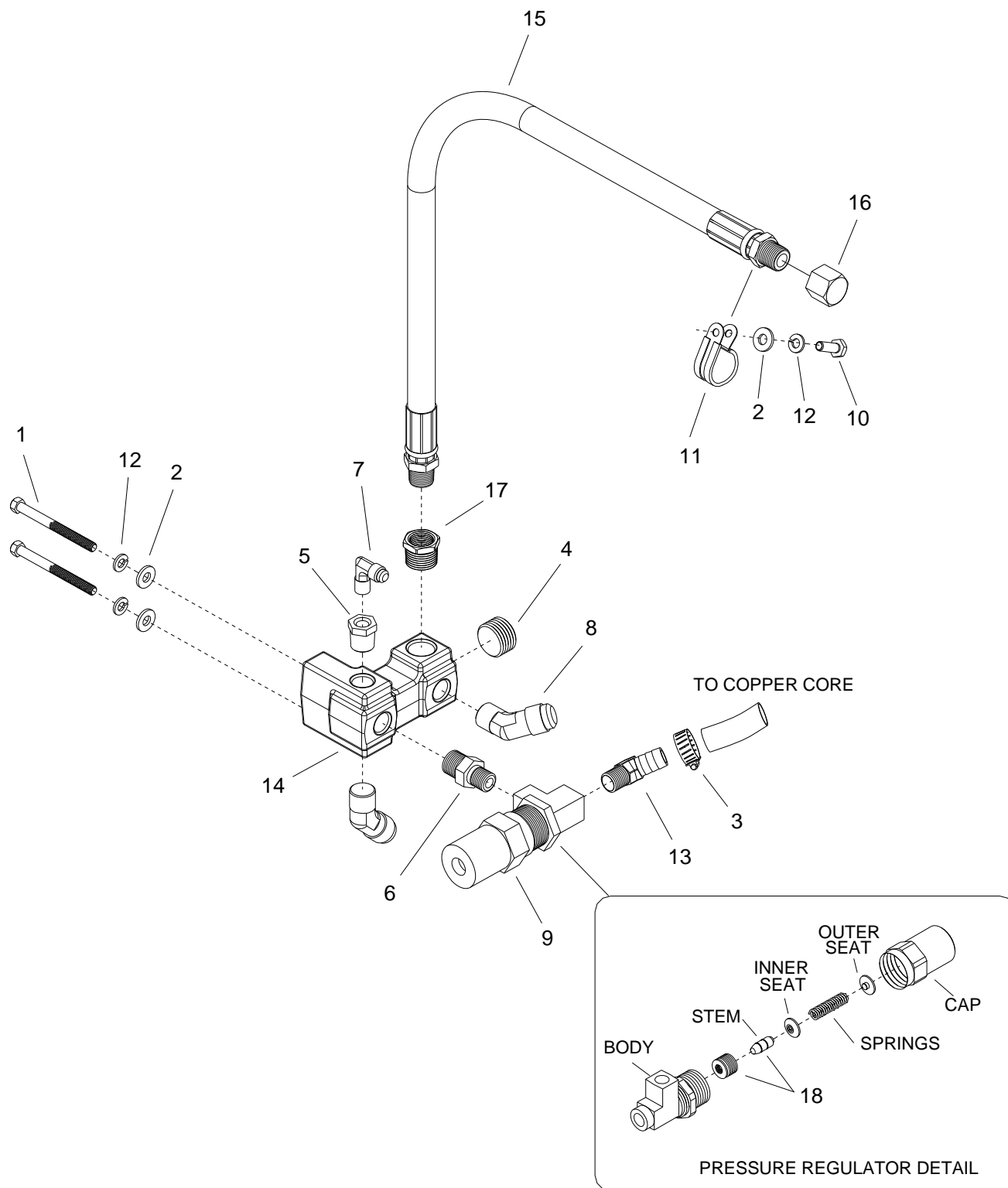

REF	PART NO.	PRV NO.	QTY	DESCRIPTION	SERIAL NO. FROM	NOTES
1	86273330	00-000286	2	SCR, CAP 1/4-20 X 2.75 HXHD		
2	86270330	02-000066	3	FLATWASHER, 1/4		
3	86177060	03-000246	1	CLAMP, HOSE, #8 SST		
4	86190480	11-800069	1	PLUG, 1/2 SOCHD BR		
5	86175920	11-800118	1	BUSH, 3/8 X 1/8 BR		
6	86188130	11-800151	1	NIPPLE, 3/8M X 1/4M		
7	86180360	12-800040	1	ELL, 1/8P X 1/4T BR		
8	86180450	12-800347	2	ELL, 3/8P X 1/2T 45 DEG. BR		
9	86191630	15-808081R	1	REG, PRESS W/DUAL SPRING		
10	86274750	70270	1	SCR, 1/4-20 X 3/4 HHCS		
11	86233390	80887	1	CLAMP, 7/8 DIA P CUSHIONED		
12	86010780	87162	3	WASHER, 1/4 SPLIT		
13	86184900	790601	1	ELBOW, 45DEG 1/4MPT x 1/2H BR		
14	86187770	790901	1	MNFLD, PRESS		
15	86312330	-	1	HOSE, PULSE 28", 3/8MPT		
16	86313740	-	1	CAP, STEEL, 3/8-18FPT		
17	86326090	-	1	BUSHING, 1/2MPT X 3/8FPT BR		
18	86186040	16-808193	1	KIT, REPAIR PRESSURE REG		

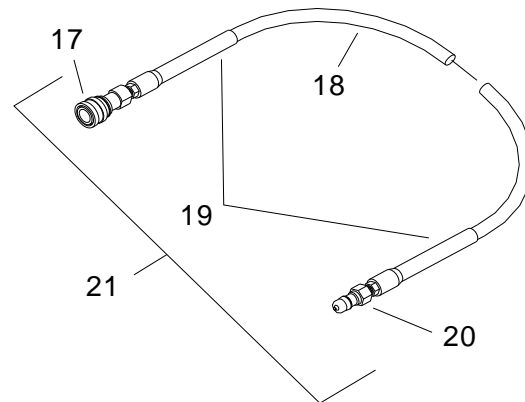
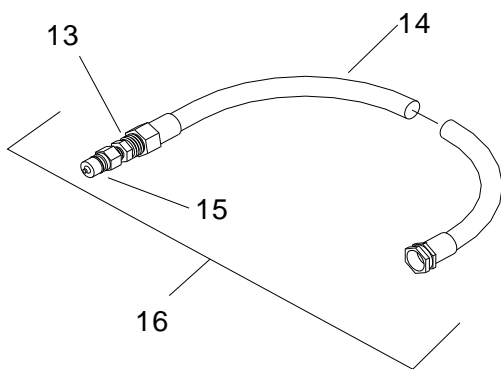
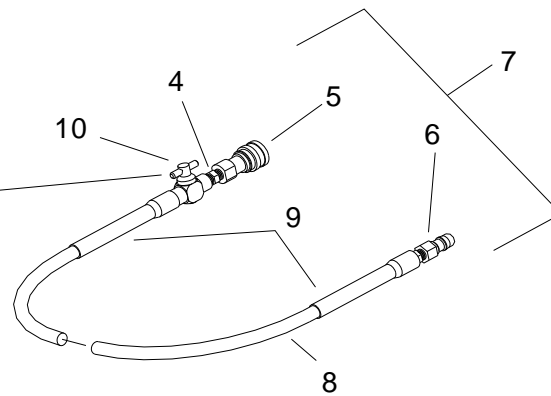
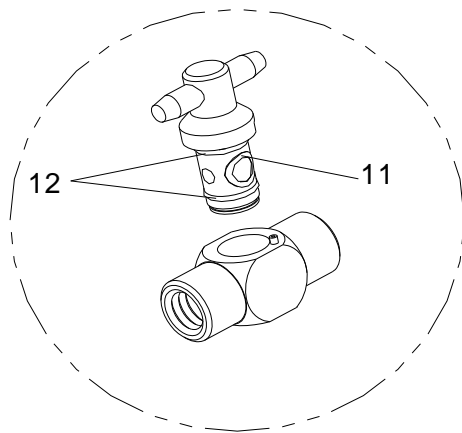
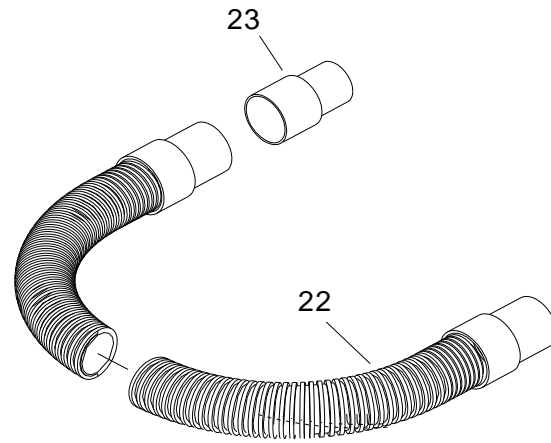
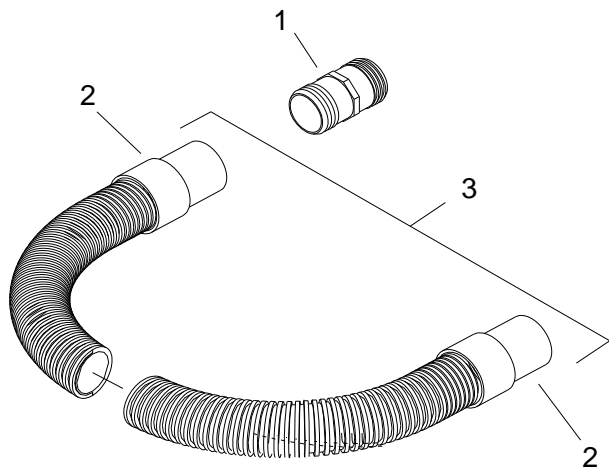

REF	PART NO.	PRV NO.	QTY	DESCRIPTION	SERIAL NO. FROM	NOTES:
1	86180980	12-800078	1	FITTING, BRB 2H BS PVC		
2	86178640	08-805147	2	CUFF, 2"		
3	86184510	10-805060	1	HOSE, VAC 2"X50' W/ CUFFS & HOSE		
4	86247680	56015	1	NIPPLE, 1/4 HEX		
5	86002450	22015	1	COUPLER, 1/4 QD		
6	86005580	56012	1	NIPPLE, 1/4 FPT QD		
7	86184530	10-805108	1	HOSE, HP 1/4 X 50FT W/QD & VLVE		
8	86184520	10-805077	1	HOSE, HP 1/4 X 50'		
9	86182800	08-805155	2	GUARD, HOSE VINYL		
10	86194990	15-808012	1	VALVE, BALL 1/4FP		
11	86189240	43-810014	2	O-RING, 7/32ID X 11/32OD		
12	86189250	43-810019	2	O-RING, 3/8 ID X 1/2 OD		
13	86188210	11-800354	1	NIP, 1/2 X 3/8 HEX BR		
14	86184570	10-805157	1	HOSE, WATER 1/2 X 50'		
15	86179630	13-806009	1	DISCONNECT 3/8M X 3/8FP		
16	86184620	10-805295	1	HOSE, WATER 1/2 X 50'		
17	86002450	22015	1	COUPLER, 1/4 QD		
18	86184520	10-805077	1	HOSE, HP 1/4 X 50'		
19	86182800	08-805155	2	GUARD, HOSE VINYL		
20	86005580	56012	1	NIPPLE, 1/4 FPT QD		
21	86184540	10-805122	1	HOSE, HP 1/4 X 50FT W/QD		
22	86328140	-	1	HOS, VAC 2-1/2" X 50' W/CUFFS &		
23	86328150	-	1	COUPLER, HOS 2-1/2" TO 2"		

60 Gallon Waste Tank

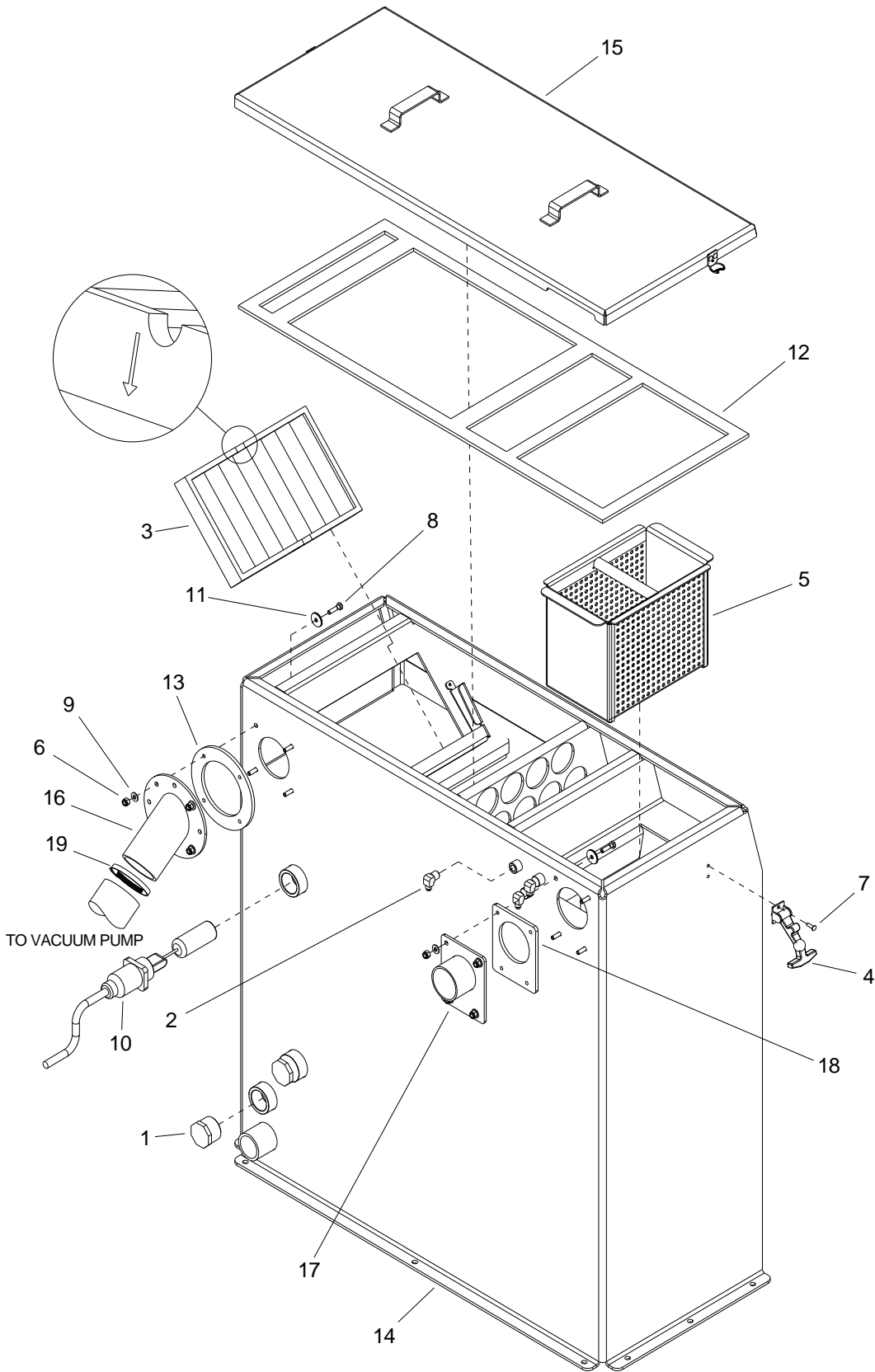

REF	PART NO.	PRV NO.	QTY	DESCRIPTION	SERIAL NO. FROM	NOTES
-	86328680	-	1	KIT, WASTE TANK 60 G, PC		COMPLETE
1	86190530	11-800402	2	PLUG, 1-1/4 HXHD PVC		
2	86180340	12-800031	3	ELL, 1/4P X 1/4T BR		
3	86193540	14-806569	1	STRNR, WST TNK, RECT, 1.5		
4	86186860	46-802510	2	LATCH, DRAW 2-7/8 SST		
5	86043190	56-501793	1	STRAINER BOWL, AVENGER 450		
6	86005810	57245	8	NUT, 1/4-20 HEX NYLOCK SS		
7	86273020	67006	8	RIVET, 3/16 OD X 5/8 AL		
8	86273810	70018	8	SCR, 1/4-20 X 1 HHCS SS		
9	86010630	87013	8	WASHER, 1/4 X 5/8 FLAT SS		
10	86193870	791066	1	ASSY, LVL SENS SHTOF SW		
11	86202240	-	8	WASHER, SEAL 1/4 X 1 OD SS		
12	86318530	-	1	GASKET, WASTE TANK LID		
13	86318560	-	1	GASKET, VAC OUTLET		
14	86320940	-	1	TANK, WASTE, 60G PC		
15	86320990	-	1	LID, WST TNK, 60G PC		
16	86321040	-	1	OUTLET, VACUUM, 2-7/8", PC		
17	86323650	-	1	INLET, 2-1/2" VACUUM, PC		
18	86323700	-	1	GASKET, VAC INLET		
19	86177010	03-000112	1	CLAMP, HOSE #48		

100 Gallon Waste Tank

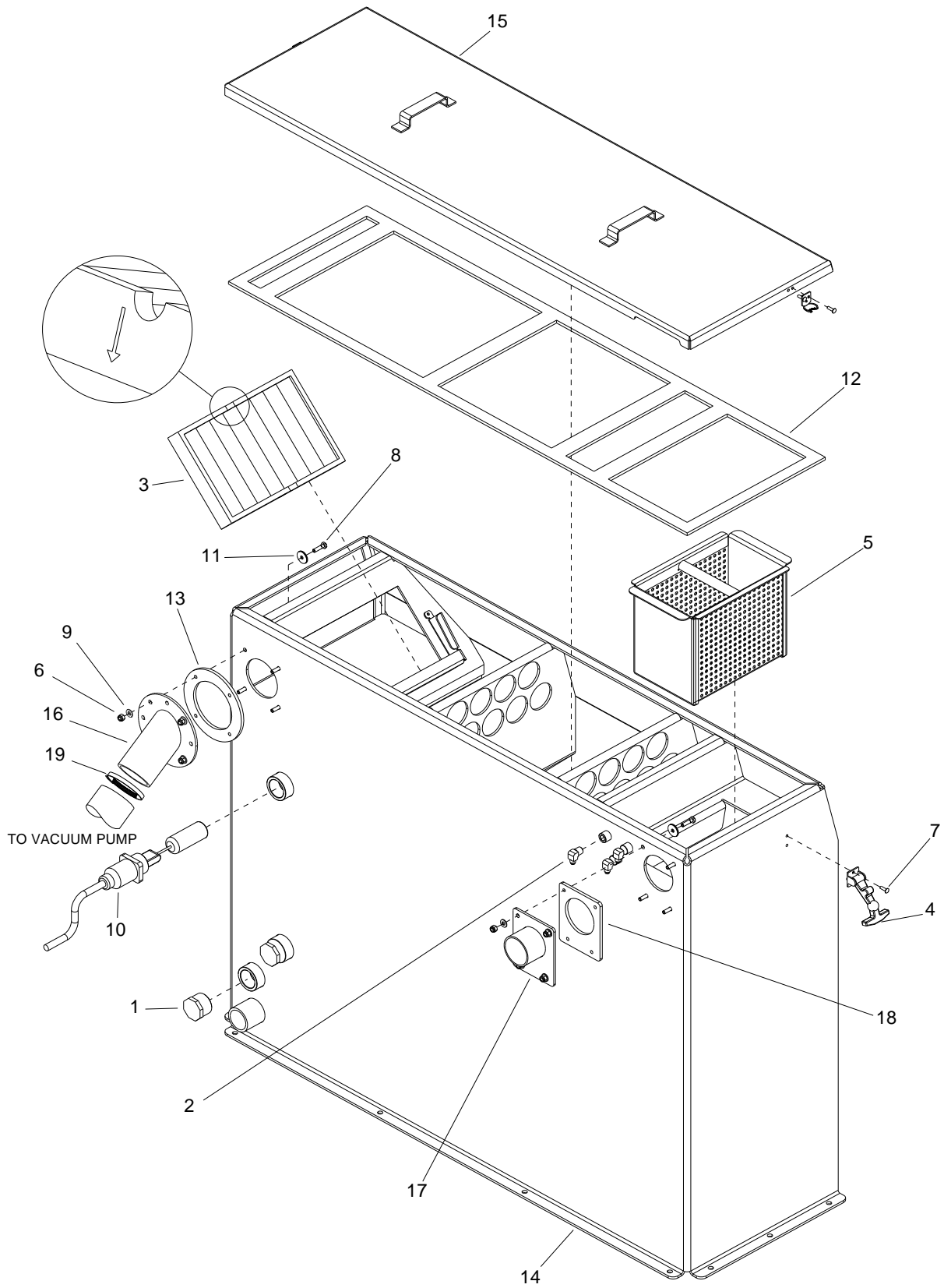

REF	PART NO.	PRV NO.	QTY	DESCRIPTION	SERIAL NO. FROM	NOTES
-	86328690	-	1	KIT, WASTE TANK 100 G, PC		COMPLETE
1	86190530	11-800402	2	PLUG, 1-1/4 HXHD PVC		
2	86180340	12-800031	3	ELL, 1/4P X 1/4T BR		
3	86193540	14-806569	1	STRNR, WST TNK, RECT, 1.5		
4	86186860	46-802510	2	LATCH, DRAW 2-7/8 SST		
5	86043190	56-501793	1	STRAINER BOWL, AVENGER 450		
6	86005810	57245	8	NUT, 1/4-20 HEX NYLOCK SS		
7	86273020	67006	8	RIVET, 3/16 OD X 5/8 AL		
8	86273810	70018	8	SCR, 1/4-20 X 1 HHCS SS		
9	86010630	87013	8	WASHER, 1/4 X 5/8 FLAT SS		
10	86193870	791066	1	ASSY, LVL SENS SHTOF SW		
11	86202240	-	8	WASHER, SEAL 1/4 X 1 OD SS		
12	86325770	-	1	GASKET, 100G LID WST TNK		
13	86318560	-	1	GASKET, VAC OUTLET		
14	86325650	-	1	TANK, WASTE, 100G PC		
15	86325720	-	1	LID, 100G WST TNK, PC		
16	86321040	-	1	OUTLET, VACUUM, 2-7/8", PC		
17	86323650	-	1	INLET, 2-1/2" VACUUM, PC		
18	86323700	-	1	GASKET, VAC INLET		
19	86177010	03-000112	1	CLAMP, HOSE #48		

Battery Floor Mount

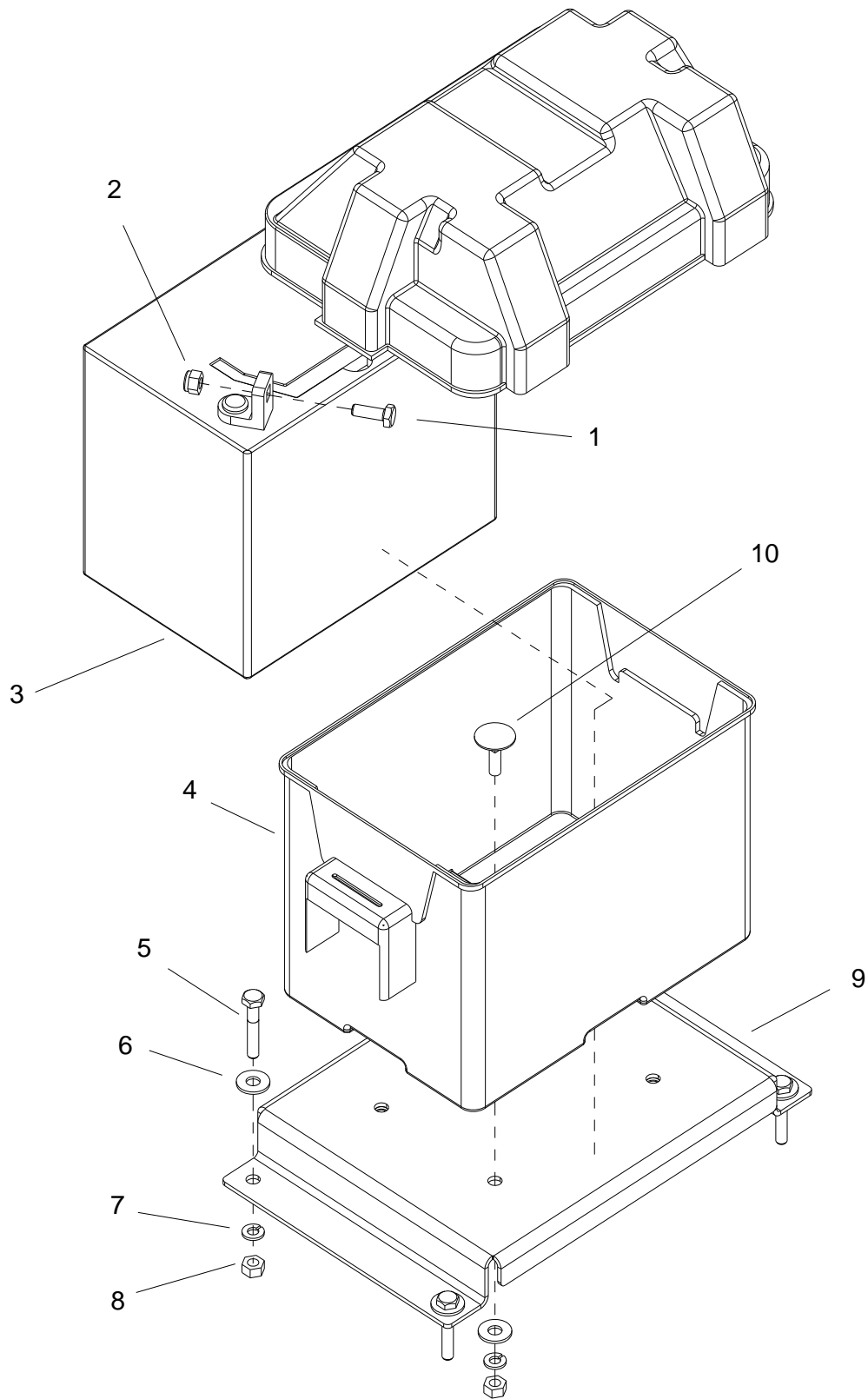

REF	PART NO.	PRV NO.	QTY	DESCRIPTION	SERIAL NO. FROM	NOTES:
-	86030550	66-945300	1	KIT,BAT FLR MTG TM		COMPLETE
1	86273780	70015	2	SCR, 1/4-20 X 3/4 HHCS SS NP		
2	86005680	57047	2	NUT, 1/4-20 HEX NYLOCK		
3	86174580	36-900056	1	BATTERY		
4	86012060	-	1	BOX, BATTERY, MODIFIED		
5	86273190	00-000132	4	SCR, 1/4-20 X 1-1/2 HXHD		
6	86270330	02-000066	8	FLATWASHER, 1/4		
7	86010780	87162	8	WASHER, 1/4 SPLIT LOCK PLTD		
8	86270770	57006	8	NUT, 1/4-20 HEX		
9	86309890	-	1	BRKT, BATTERY BOX MTG		
10	86011470	-	4	BOLT, ELEVATOR, 1/4-20 X 1		

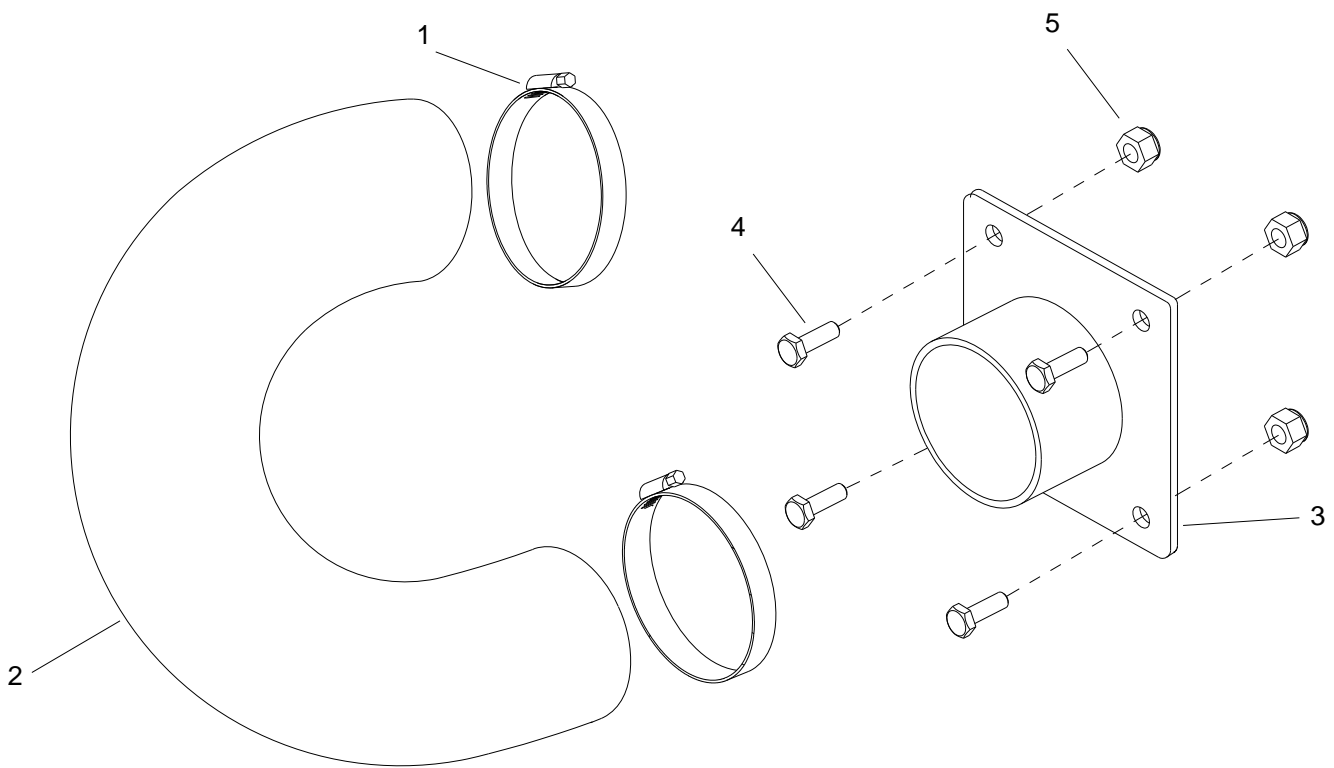

REF	PART NO.	PRV NO.	QTY	DESCRIPTION	SERIAL NO. FROM	NOTES
1	86177010	03-000112	2	CLAMP, #48 HOSE		
2	86280600	09-805487	1	HOSE, 3" X 17" FLEXABLE		
3	86181110	56-502131	1	FLANGE, VAC EXH DUCT KIT LG		
4	86192060	00-000376	4	SCREW, 1/4-20 X 1-1/4" SST		
5	86005810	57245	4	NUT, 1/4-20 HEX NYLOCK SS		
-	86030440	47447	1	KIT, EXHAUST 3"ID, SINGLE		KIT COMPLETE

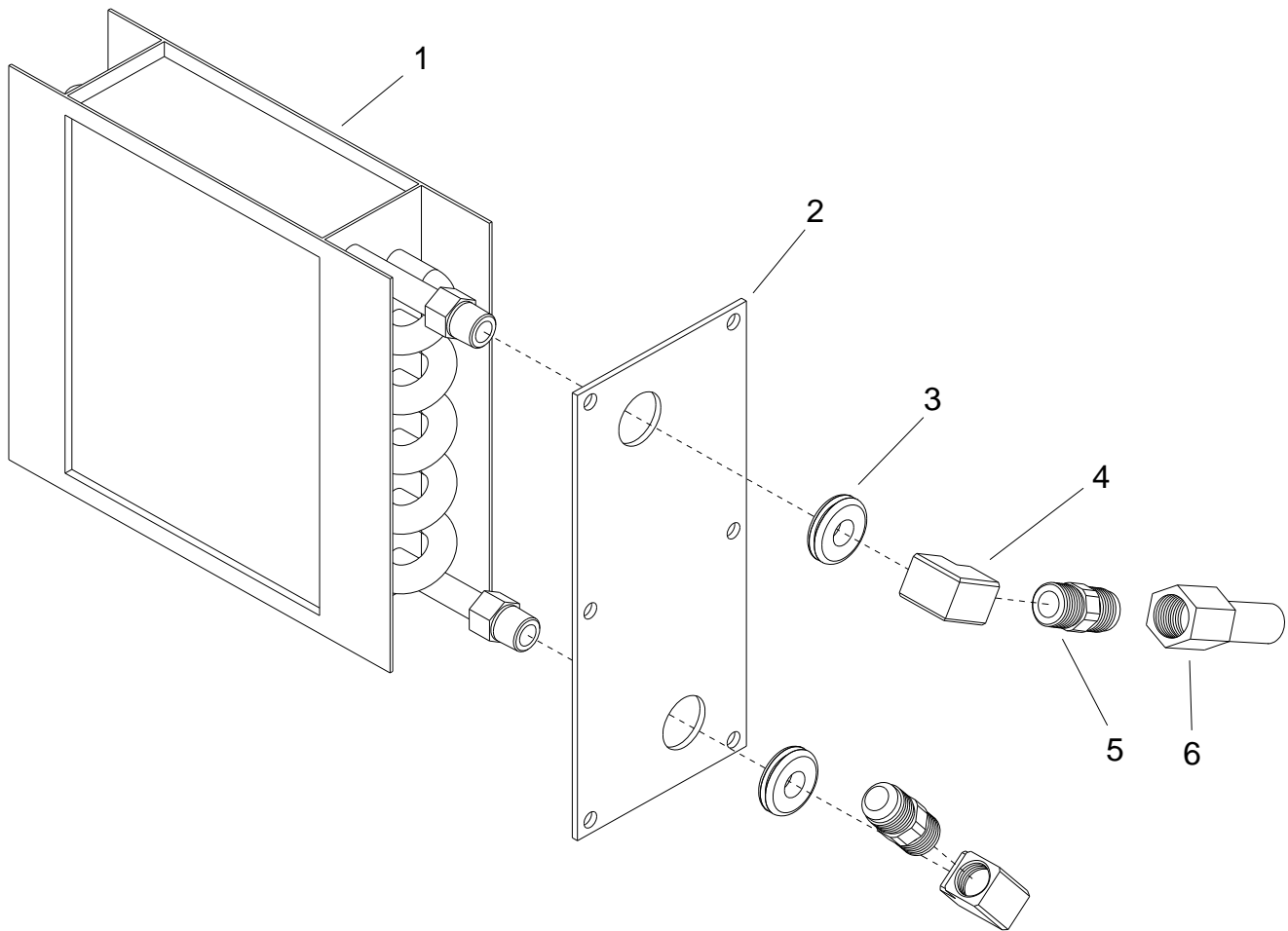

REF	PART NO.	PRV NO.	QTY	DESCRIPTION	SERIAL NO. FROM	NOTES
-	86328070	-	1	KIT, 3RD HEAT EXCHANGER, PEAK GT		COMPLETE
1	86043150	790388	1	ASSEMBLY, HEATER CORE SS		
2	86051220	620023	1	PLATE, HTR CORE CVR, STL		
3	86182190	36238	2	GROM, 1/2 ID X 1-1/8 OD		
4	86180220	11-800276	2	ELL, 3/8 BR		
5	86177700	12-800282	2	CONN, 3/8P X 1/2T BR		
6	86328030	-	1	HOSE, 1/2 X 7" SS W/SLC CVR		

Automatic Pumpout - Optional

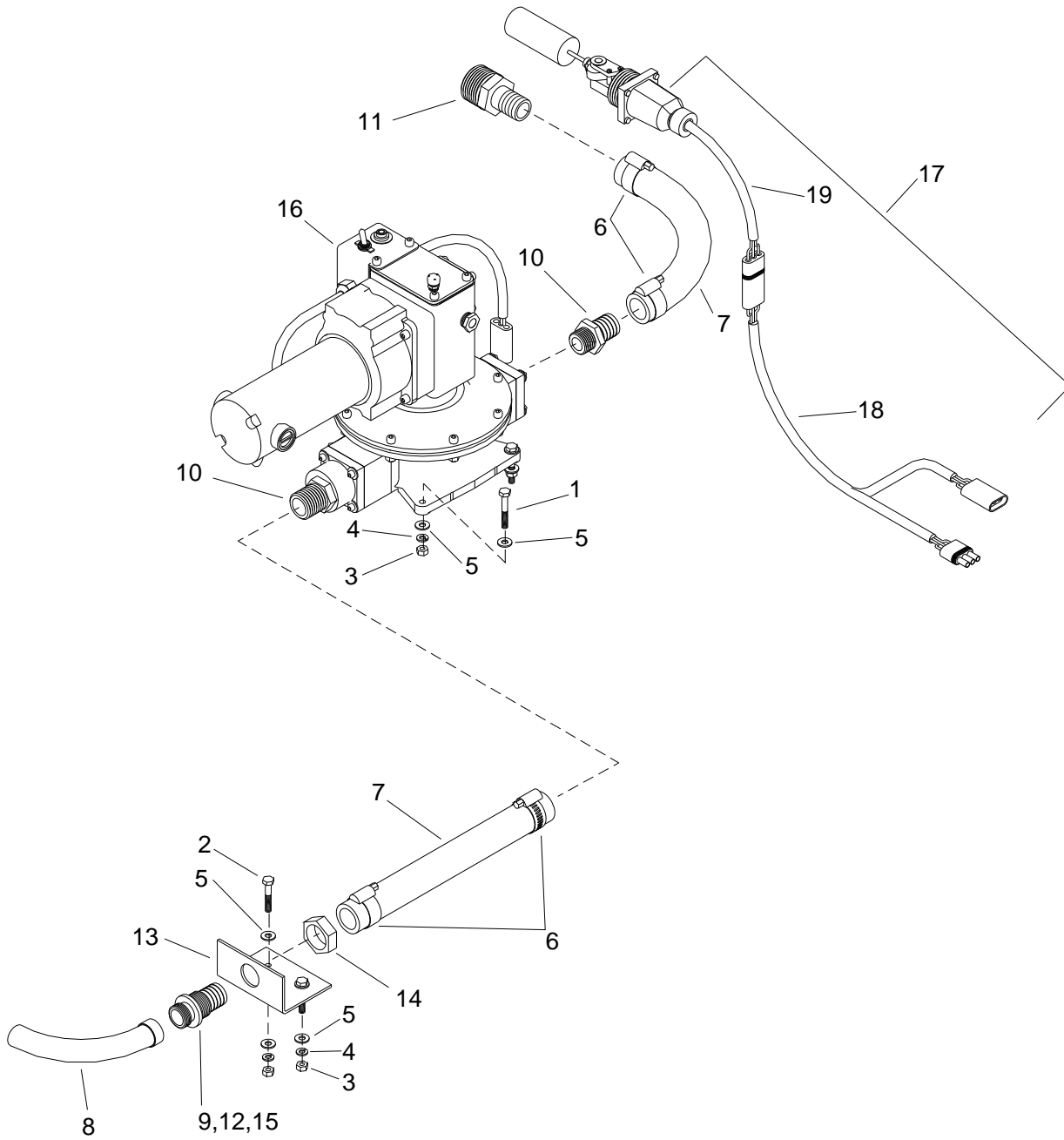

REF	PART NO.	PRV NO.	QTY	DESCRIPTION	SERIAL NO. FROM	NOTES:
-	86284990	66-945533	1	H.D. WASTE PUMP OUT		COMPLETE
1	86274150	70105	4	SCR, 1/4-20 X 1.75 HHCS PLTD		
2	86273190	00-000132	2	SCR, 1/4-20 X 1-1/2 HXHD		
3	86270770	57006	4	NUT, 1/4-20 HEX		
4	86010780	87162	4	WASHER, 1/4 SPLIT LOCK PLTD		
5	86270330	02-000066	4	FLATWASHER, 1/4		
6	86177050	03-000176	4	CLAMP, HOSE #16		
7	86280680	09-805591	1	HOSE, WASTE PUMP 1" X 8'		
8	86184780	10-805484	1	HOSE, GARDEN 3/4 X 75'		
9	86176420	12-800052	1	CAP, HOSE 3/4 BR		
10	86181430	12-800367	1	FTTG, BRB 1PX1H BR		
11	86181440	12-800444	1	FTTG, 1-1/4P X 1" H BR		
12	86195820	43-807008	1	WASHER, HOSE 5/8 ID 1" OD		
13	86175720	50-502055	1	BRKT, PUMP-OUT HOS CONN		
14	86188970	52-000123	1	NUT, 1-3/16-12 UN HXHD		
15	86162270	52-501993	1	CONN, HOSE WATER OUTL		
16	86191380	61-951306	1	PUMP, HD AUTO		
17	86174260	61-951319	1	ASSY, LVL SENS SHUT OFF SW		
18	86195860	23719	1	CORD ASM, CNCTN SIDE		
19	86195910	72185	1	SWITCH ASSEMBLY		

Automatic Pumpout - Optional

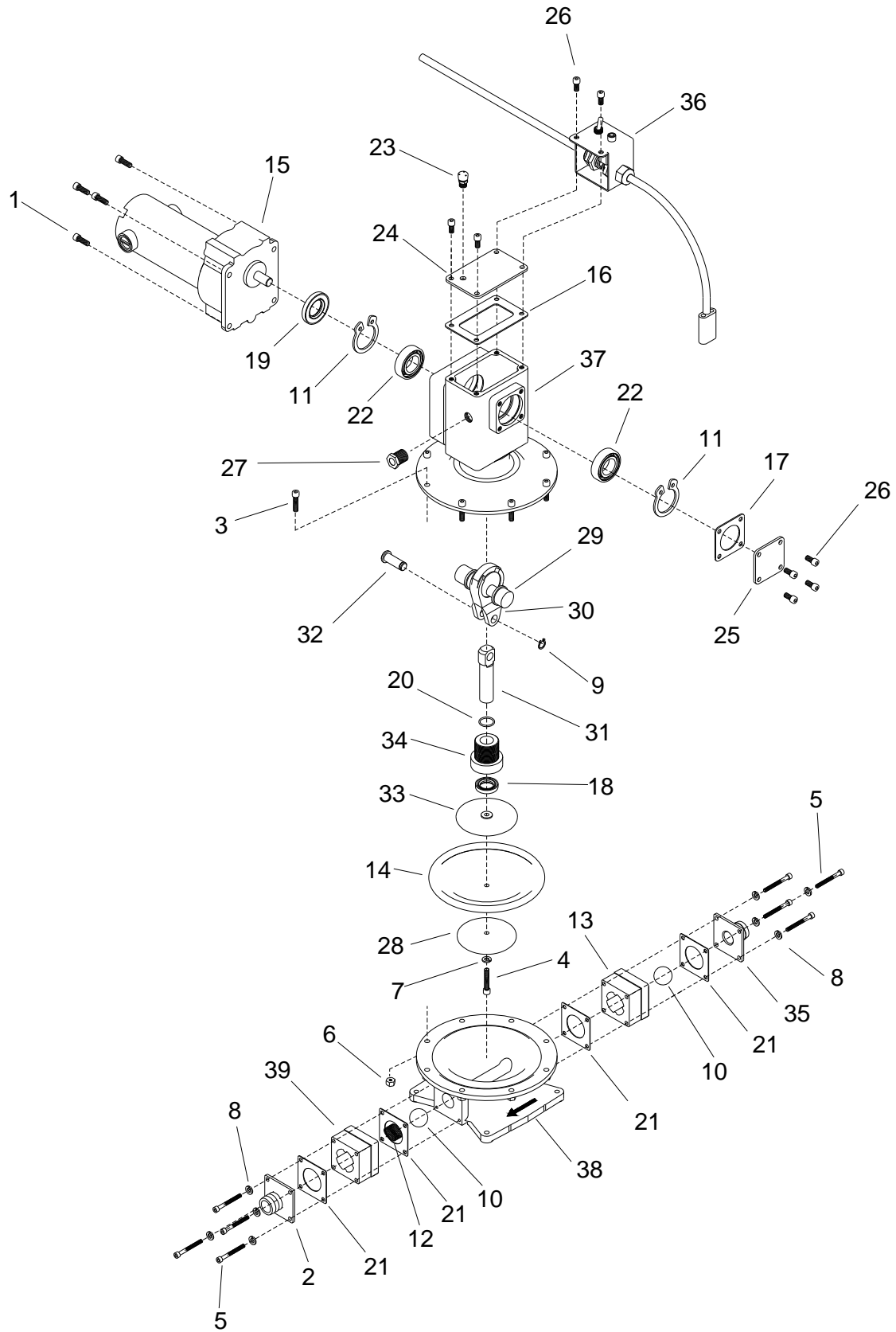

REF	PART NO.	PRV NO.	QTY	DESCRIPTION	SERIAL NO. FROM	NOTES:
1	86273250	00-000210	4	SCR, 1/4-20 X 3/4 SOCHD		
2	86178820	52-502064	1	CVR, OUTLET WST PMP-OUT		
3	86192020	00-000312	8	SCR, CAP 1/4 X 1 SOCHD		
4	86273550	00-000399	1	SCR, CAP 1/4 X 1 3/8 SOC		
5	86273280	00-000241	8	SCR, CAP 10-32 X 2 SOCHD SS		
6	86005810	57245	8	NUT, 1/4-20 HEX NYLOCK SS		
7	86010780	87162	1	WASHER, 1/4 SPLIT LOCK		
8	86279470	87165	8	WASHER, #10 SPLIT LOCK		
9	86024840	04-000312	1	RING, RETAIN EXT 1/2		
10	86174520	04-000334	2	BALL, NYL ID		
11	86024850	04-000335	2	RING, SNAP 1-7/8D		
12	86193250	04-000342	1	SPRING, PUMP-OUT BALL PRESS		
13	86174700	52-502061	1	BDY, INLET WST PMP-OUT		
14	86179530	16-808241	1	DIAPH, WST TNK PMP-OUT		
15	86187870	40-902151	1	MOTOR, 1/8HP 12V		
16	86182540	43-807117	1	GSKT, CVR TOP PMPOUT		
17	86182550	43-807118	1	GSKT, CVR SD PMPOUT		
18	86192300	43-810091	1	SEAL, PUMPOUT SHFT		
19	86192350	43-810100	1	SEAL PUMPOUT CAM		
20	86189600	43-810101	1	O-RING, 800/1000 .072		
21	86182530	43-807116	4	GSKT,IN/OUTLT WST TNK-PM		
22	86175530	45-801927	4	BRG, SHFT PUMP-OUT		
23	86195190	49-876301	1	VENT, UPR SHFT BRNG HSG		
24	86050890	50-502025	1	PL, CVR TOP PUMP-OUT		
25	86024860	50-502026	1	PL, CVR SD PUMP-OUT		
26	86274110	70094	8	SCR, 1/4-20 X 1/2 SHCS SS		
27	86181680	11-800504	1	GA, FLOW SIGHT 3/8 NPT		
28	86175830	52-501828	1	BTM, PLNGR WST TNK PMP-OUT		
29	86192690	52-501829	1	SHFT, 3/4" STROKE WST TNK		
30	86191550	52-501914	1	RD, CONNECT WST PMP-OUT		PART OF 31
31	86182810	52-501915	1	GUIDE, PLNGR WST PUMP-OUT		INCL. 32, 18, 30
32	86024870	52-501921	1	PIN, WRIST PUMP-OUT		
33	86194640	52-501934	1	TOP, PLNGR PUMP-OUT		
34	86176020	52-501950	1	BUSH, THREADED		
35	86178810	52-502062	1	CVR, INLET WST PMP-OUT		
36	86045790	56-502428	1	BRKT, PMP-OUT SW/CCT BRKR		
37	86024880	52-501821	1	TOP, WST TNK PUMP-OUT		
38	86174550	52-501820	1	BASE, WST TANK PMP-OUT		
39	86174710	52-502063	1	BDY, INLET WST PMP-OUT		

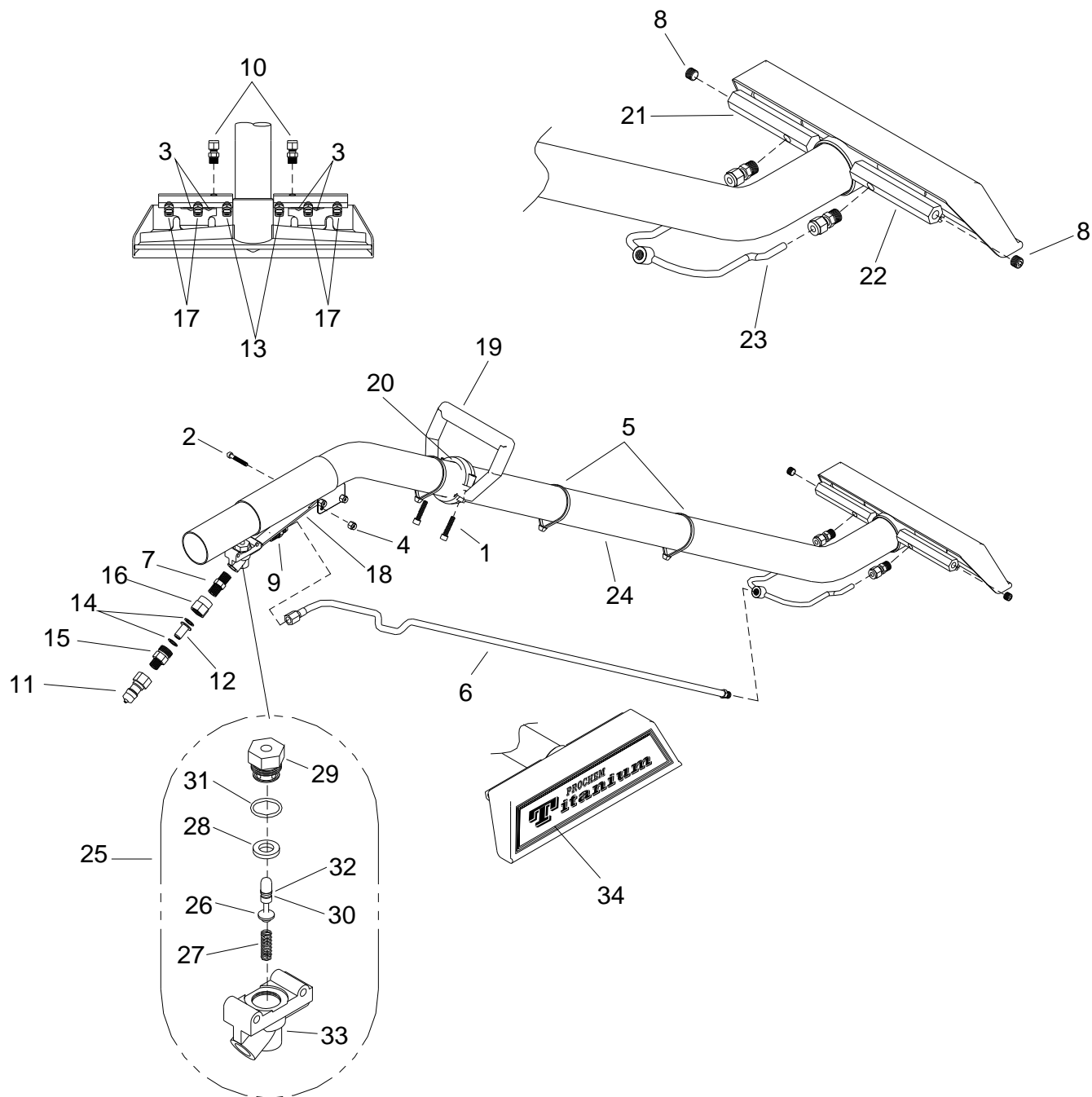

REF	PART NO.	PRV NO.	QTY	DESCRIPTION	SERIAL NO. FROM	NOTES:
-	86288350	89248	1	WD, TM, 6 JET, TITANIUM (8001) PC		COMPLETE
1	86273310	00-000282	2	SCR, CAP 1/4-20 X 1 1/4 SOC		
2	86192030	00-000317	2	SCR, CAP 10-32 X 1 1/4 SOCH		
3	86006680	70228	4	SCR, 10-32 X 1/4 PPHMS SS		
4	86270990	57090	2	NUT, 10-32 HEX NYLOCK SS		
5	86264910	04-000093	2	TIE, CABLE 13"		
6	86184270	10-805504	1	HOSE, 3/16 X 44-1/2		
7	86247680	56015	1	NIPPLE, 1/4 HEX		
8	86190180	11-800206	2	PLUG, 1/8 SOCHD BR		
9	86177650	12-800060	1	CONN, 1/4P X 1/4T BR		
10	86177710	12-800322	2	CONN, 1/8P X 1/4T COMP BR		
11	86005580	56012	1	NIPPLE, 1/4 FPT QD		
12	86193490	14-806512	1	STRAINER, JET 50 MESH		
13	86194450	17-803018	2	TIP, SPRAY 9501 X 1/8P SST		
14	86195570	17-803006	2	WASHER, NYLON		
15	86177860	17-803010	1	CONN, 1/4P X 11/16-16M		
16	86177870	17-803036	1	CONN, 1/4FP X 11/16-16F BR		
17	86194580	17-803078	4	TIP, SPRAY 8001 SST \1/8 VJET		
18	86194650	52-501619	1	TRIGGER, WD VALVE		
19	86174680	52-502008BK	1	BODY, WD HDL, 2" TB, BK		
20	86198180	52-502009	1	HOLD DN-WD HDL 2" TUBE		
21	86187610	52-502057	1	MANFOLD, LEFT		
22	86187620	52-502058	1	MANIFOLD, RIGHT		
23	86174060	56-502548	1	ASSY, MNFLD S-BEND		
24	86285440	56-502534	1	WD & HD, TITANIUM		
25	86174120	61-950496	1	ASSY, EXTRACTOR VALVE		
26	86193360	16-808189	1	STEM, EXTRACTOR VALVE		
27	86193200	16-808190	1	SPRING, EXTRACTOR VALVE		
28	86192410	16-808228	1	SEAT, EXTRACTOR VALVE		
29	86183160	16-808229	1	HLDR, VLV STEM-EXTRACTOR VL		
30	86189510	43-810062	1	O-RING, .114 ID .254OD		
31	86189520	43-810063	1	O-RING, .551ID .691OD		
32	86174500	43-810064	1	BACK-UP, .250DIA		
33	86174630	52-501590	1	BDY, EXTRACTOR VLV		
34	86179250	48-941462	1	DEC, WD HD TITANIUM		

Wand - Ergo Titanium Six Jet - Optional

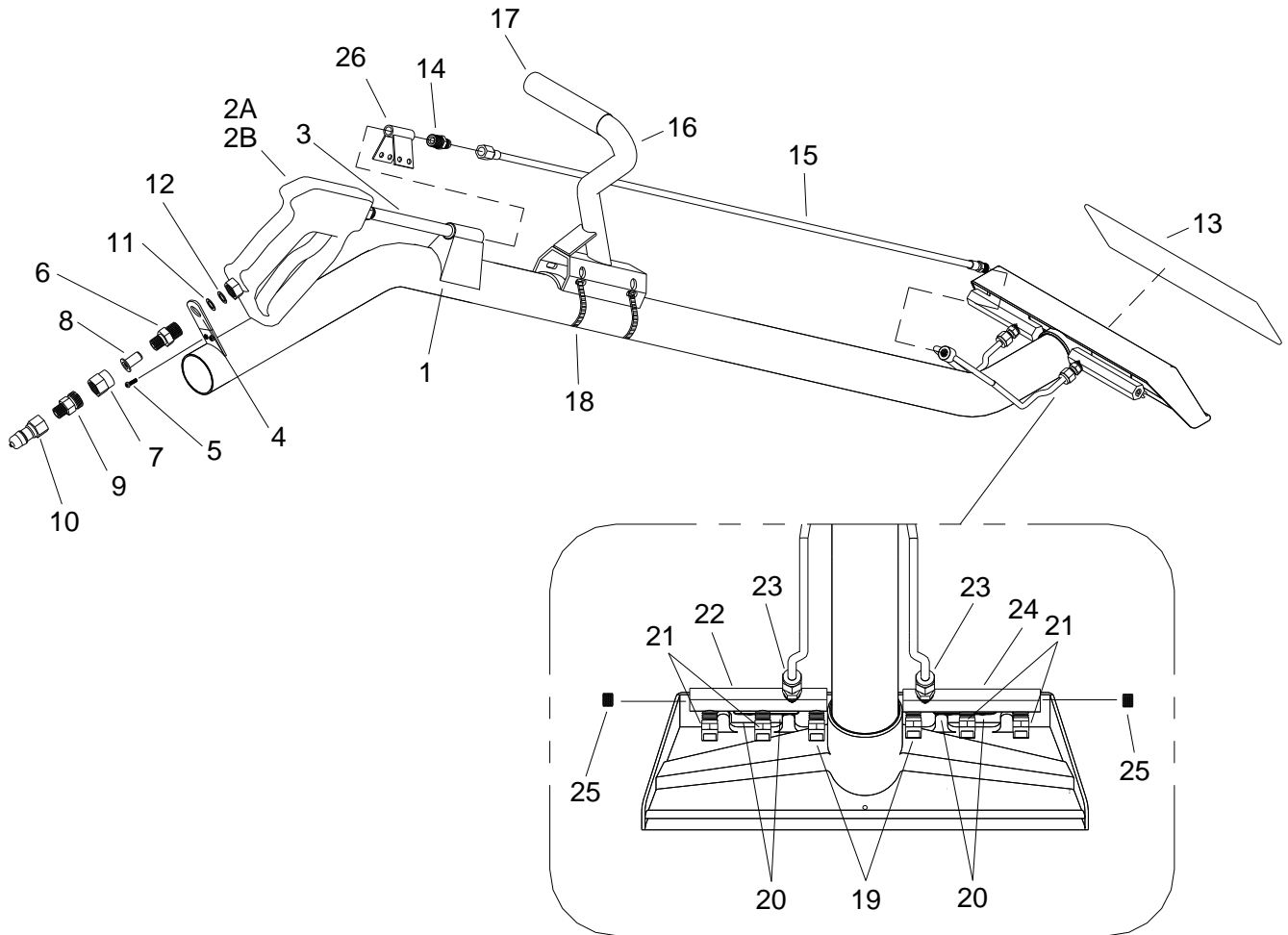

REF	PART NO.	PRV NO.	QTY	DESCRIPTION	SERIAL NO. FROM	NOTES
-	86326900	-	1	WAND, ERGO TI		COMPLETE
1	86195560	791121	1	WAND/HEAD WELDMENT		
2A	86182820	17-803025	1	GUN, PRESS WASH TM		
2B	86011740	-	1	YG5000 SPRAY GUN ASM		
3	86188590	791122	1	NIPPLE, 1/4 X 5 SS		
4	86175760	791123	1	BRKT, HNDL, CLMP		
5	86277760	791124	2	SCR, 8-32 X 1/4 SHCS SS		
6	86188280	11-800381	1	NIP, 3/8 X 1/4 HX SST		
7	86177870	17-803036	1	CONN, 1/4FP X 11/16-16F BR		
8	86193490	14-806512	1	STRNR, JET 50 MESH		
9	86177860	17-803010	1	CONN, 1/4 X 11/16-16M		
10	86005580	56012	1	NIP, 1/4 FPT QD		
11	86195600	791127	1	WASHER, BLK WD		
12	86195610	791128	1	WASHER, FLAT SS WD		
13	86179020	48-941186	1	DEC, WD HD (CAST SST) TM		
14	86177650	12-800060	1	CONN, 1/4P X 1/4T BR		
15	86031580	10-805245	1	HOSE, 3/16 X 40-1/2		
16	86183110	46-802553	1	HDL, TITANIUM WND W/SPYR		
17	86182120	791125	1	GRIP, BLU HANDLE		
18	86177150	791126	2	CLAMP, #38 HOSE SS		
19	86194450	17-803018	2	TIP, SPRY 9501 X 1/8P SST		
20	86270990	57090	4	NUT, 10-32 HEX SS NYLOCK		
21	86194580	17-803078	4	TIP, SPRAY 8001 SST 1/8 VJE		
22	86187620	52-502058	1	MNFLD, LT TITAN		
23	86177710	12-800322	2	CONN, 1/8P X 1/4T COMP BR		
24	86187610	52-502057	1	MNFLD, RT TITAN		
25	86190180	11-800206	2	PLG, 1/8 SOCHD BR		
26	86175660	140160	1	BRKT, MANIFOLD, WAND		
-	86186100	47453	1	KIT, REPAIR 17-803025		NOT SHOWN

Wand - Quad Jet - Optional

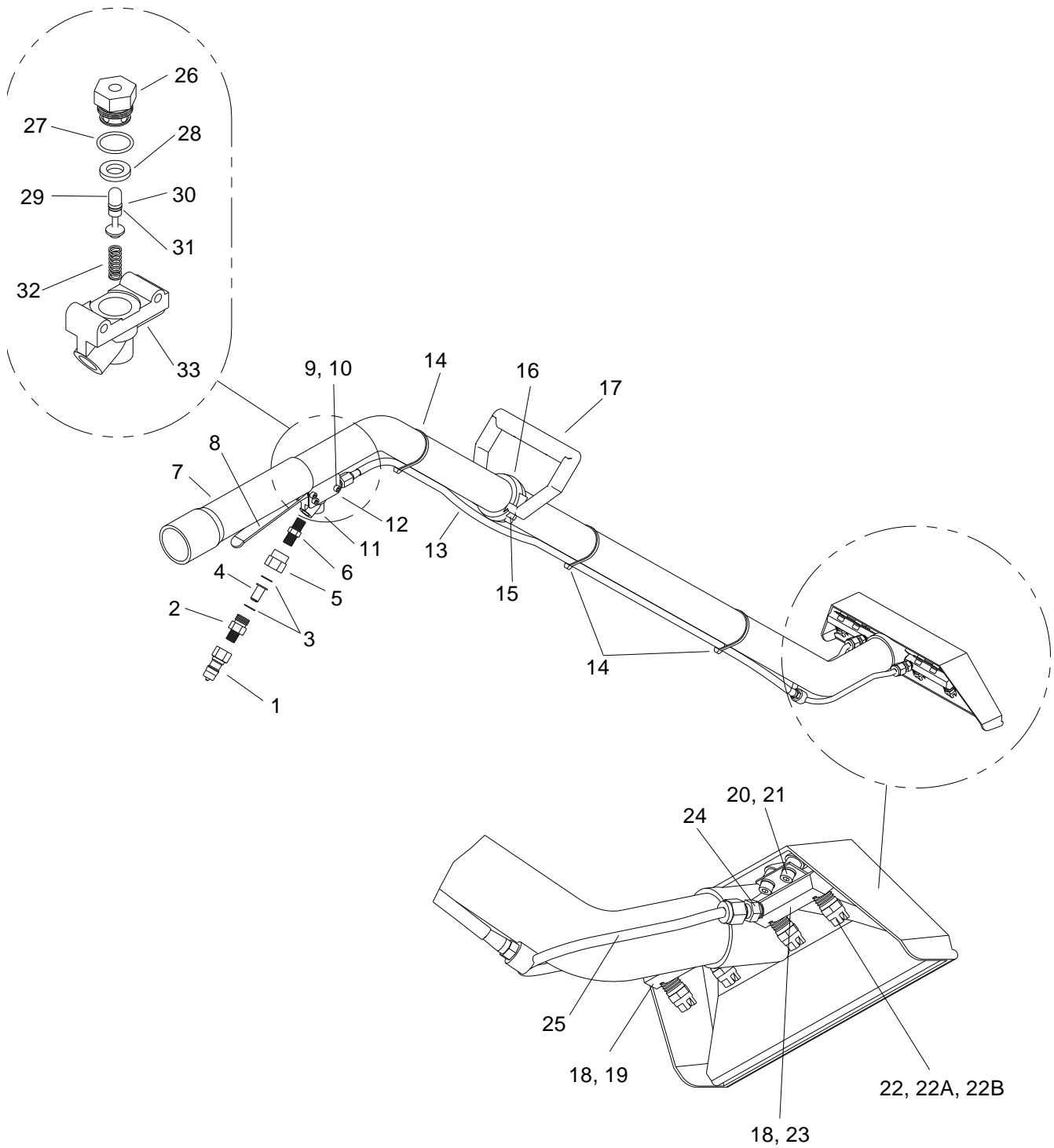

REF	PART NO.	PRV NO.	QTY	DESCRIPTION	SERIAL NO. FROM	NOTES:
-	86285570	89238	-	WAND, TM, QJW (95015) PC		COMPLETE
-	86285580	89239	-	WAND, TM, QJW (9502) PC		COMPLETE
-	86285560	89237	-	WAND, TM QJW (9501) PC		COMPLETE
-	86285540	89235	-	WAND, TM, QJW, (9501) NO DECAL		COMPLETE
1	86005580	56012	-	NIPPLE, 1/4 FPT QD		
2	86177860	17-803010	1	CONN, 1/4P X 11/16-16M		
3	86195570	17-803006	1	WASHER, NYLON		
4	86193490	14-806512	2	STRAINER, JET 50 MESH		
5	86177870	17-803036	1	CONN, 1/4FP,11/16-16R BR		
6	86247680	56015	1	NIPPLE, 1/4 HEX		
7	86280020	09-805359	1	SLEEVE, WD HDL 9.5		
8	86194650	52-501619	1	TRIGGER, WD VLV		
9	86192030	00-000317	3	SCR, CAP 10-32X 1-1/4 SOCH		
10	86270990	57090	3	NUT, 10-32 HEX NYLOCK SS		
11	86174120	61-950496	1	ASSY, EXTRCTR VLV		
12	86177650	12-800060	1	CONN, 1/4P X 1/4T BR		
13	86183970	10-805387	1	HOSE, 3/16 X 43-1/2 (1/8P X 1/4)		
14	86265730	04-000053	3	TIE, CABLE 8" WHT		
15	86273310	00-000282	2	SCR, CAP 1/4-20 X 1-1/4 SOC		
16	86198160	52-501569	1	HOLD DOWN, WD HDL		
17	86182840	791150	1	BODY, WD HDL		
18	86190180	11-800206	2	PLUG, 1/8 SOCHD BR		
19	86043300	56-501966	1	ASSY, L S-BEND MNFLD		
20	86273450	00-000347	4	SCR, CAP 10-24 X1/4 SOCHD		
21	86279470	87165	4	WASHER, #10 SPLIT LOCK		
22	86194400	17-803001	4	TIP, SPRY 95015X1/8P SST		89238
22A	86194410	17-803002	4	TIP, SPRY 9502X1/8P SST		89239
22B	86194450	17-803018	4	TIP, SPRY 9501X1/8P SST		89237 89235 (NO DECAL)
23	86043310	56-501986	1	ASSY, RT S-BEND MNFLD		
24	86177710	12-800322	2	CONN, 1/8PX1/4T COMP BR		
25	86174030	56-501967	1	ASSY, S-BEND MNFLD		
26	86183160	16-808229	1	HOLDER, VLV STEM-EXTRCTR VL		
27	86189520	43-810063	1	O-RING, .551 ID .691 OD		
28	86192410	16-808228	1	SEAT, EXTRCTR VLV		
29	86193360	16-808189	1	STEM, EXTRCTR VLV		
30	86174500	43-810064	1	BACK-UP, .250 DIA		
31	86189510	43-810062	1	O-RING, .144 ID .254 OD		
32	86193200	16-808190	1	SPRING, EXTRCTR VLV		
33	86174630	52-501590	1	BODY, EXTRCTR VLV		
-	86179020	48-941186	1	DECAL, WD HD (CAST SS)		
-	86186160	66-808169	-	KIT, REP-WD VLV		INCLUDES PARTS 27-29 & 31-33

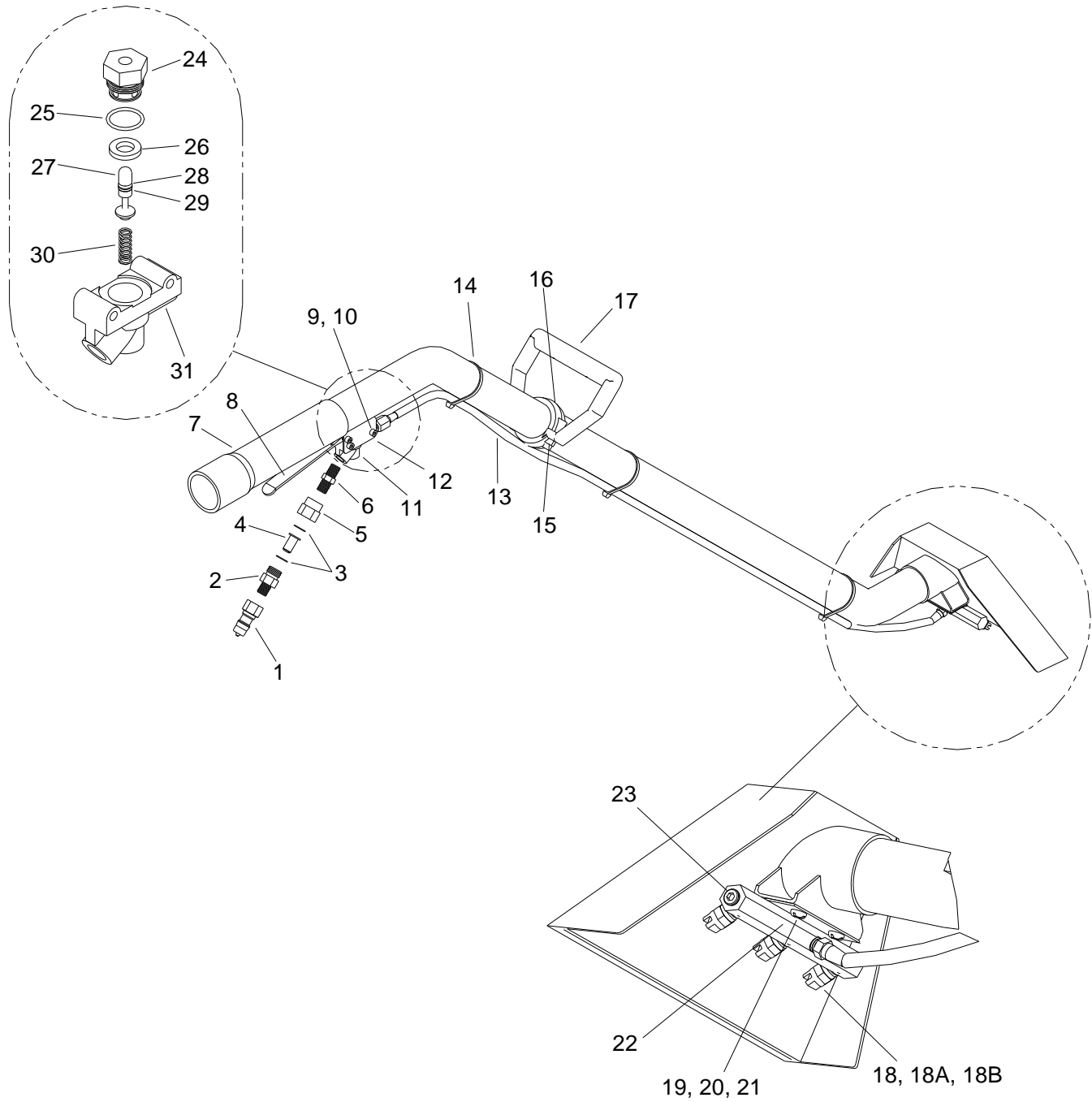

REF	PART NO.	PRV NO.	QTY	DESCRIPTION	SERIAL NO. FROM	NOTES:
-	86285520	89233	-	WAND, TJW (9502) PC		COMPLETE
-	86285510	89232	-	WAND, TJW, (95015) CUBXL		COMPLETE
-	86285530	89234	-	WAND, TJW, (9503) PC		COMPLETE
1	86005580	56012	1	NIPPLE, 1/4 FPT QD		
2	86177860	17-803010	1	CONN, 1/4P X 11/16-16M		
3	86195570	17-803006	2	WASHER, NYLON		
4	86193490	14-806512	1	STRAINER, JET 50MESH		
5	86177870	17-803036	1	CONN, 1/4FP, 11/16-16R BR		
6	86247680	56015	1	NIPPLE, 1/4 HEX		
7	86280020	09-805359	1	SLEEVE, WD HDL 9.5		
8	86194650	52-501619	1	TRIGGER, WD VLV		
9	86192030	00-000317	3	SCR, CAP 10-32X 1-1/4 SOCH		
10	86270990	57090	3	NUT, 10-32 HEX NYLOCK SS		
11	86174120	61-950496	1	ASSY, EXTRCTR VLV		
12	86177650	12-800060	1	CONN, 1/4P X 1/4T BR		
13	86183970	10-805253	1	HOSE, 3/16X49 (1/8P X 1/4FT)		
14	86265730	04-000053	3	TIE, CABLE 8" WHT		
15	86273310	00-000282	1	SCR, CAP 1/4-20 X 1-1/4 SOC		
16	86198160	52-501569	1	HOLD DOWN, WD HDL		
17	86182840	791150	1	BODY, WD HDL		
18	86194410	17-803002	3	TIP, SPRY 9502X1/8P SST		89233
18A	86194400	17-803001	3	TIP, SPRY 9501X1/8P SST		89232
18B	86194520	17-803046	3	TIP, SPRY 9503X1/8P SST		89234
19	86274290	70162	2	SCR, 10-32 X 3/8 PPHMS SS		
20	86279470	87165	2	WASHER, #10 SPLIT LOCK		
21	86270800	57014	2	NUT, 10-32 HEX SS		
22	86187700	56-501739	1	MANIFOLD, WD TRI-JET		
23	86190180	11-800206	2	PLUG, 1/8 SOCHD BR		
24	86183160	16-808229	1	HOLDER, VLV STEM-EXTRCTR VL		
25	86189520	43-810063	1	O-RING, .551 ID .691 OD		
26	86192410	16-808228	1	SEAT, EXTRCTR VLV		
27	86193360	16-808189	1	STEM, EXTRCT VLV		
28	86174500	43-810064	1	BACK-UP, .250DIA		
29	86189510	43-810062	1	O-RING, .114ID .254OD		
30	86193200	16-808190	1	SPRING, EXTRCTR VLV		
31	86179020	52-501590	1	BODY, EXTRCTR VLV		
-	86179020	48-941166	-	DECAL, WD HD		
-	86186160	66-808169	-	KIT, REP-WD VLV		INCLUDES PARTS 25-27 & 29-31

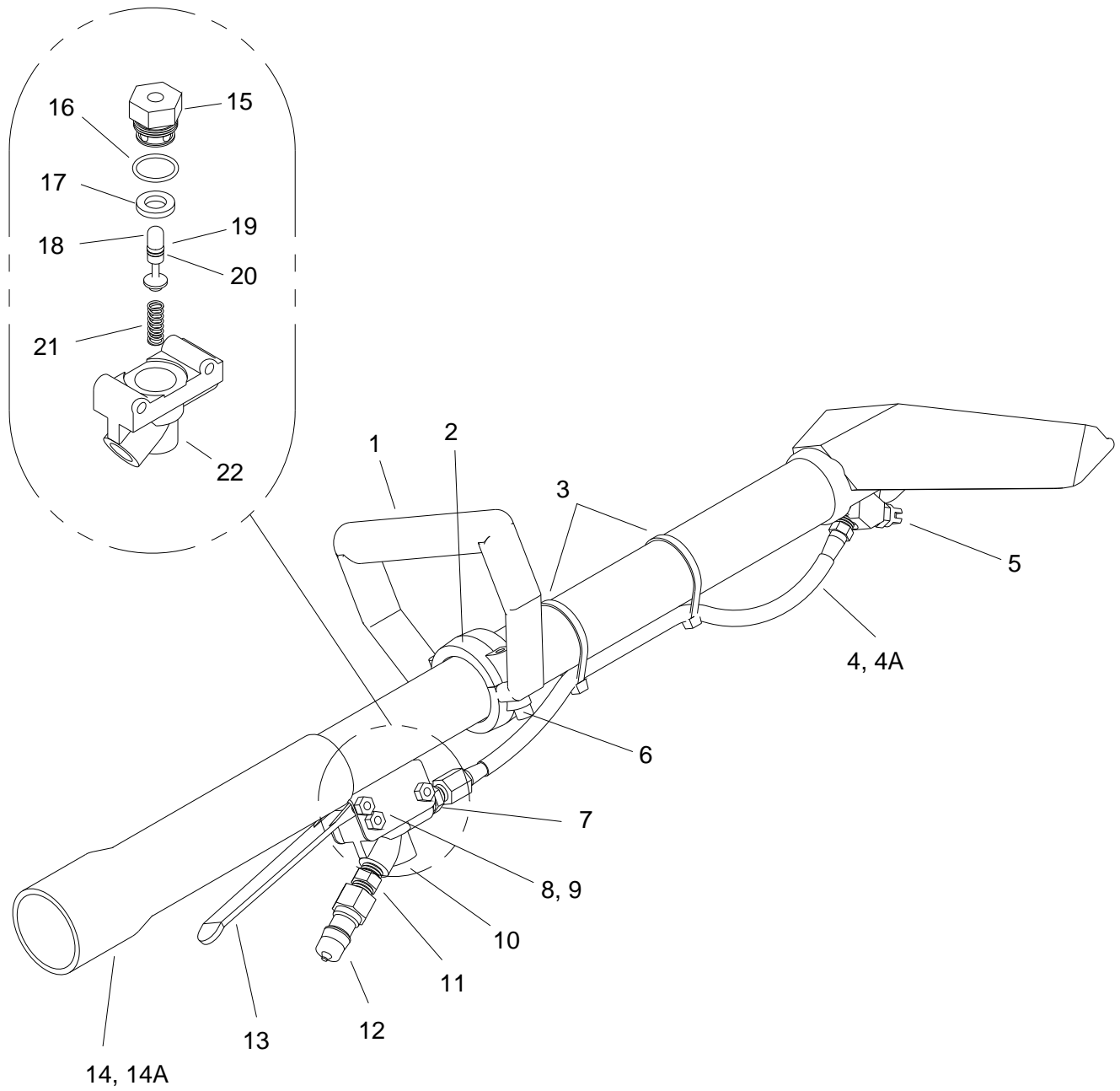

REF	PART NO.	PRV NO.	QTY	DESCRIPTION	SERIAL NO. FROM	NOTES:
-	86285350	78519	-	TL, STAIR, LNG, TM DJ (80015)		COMPLETE
-	86285290	78521	-	TL, STAIR, SHT, TM (80015)		COMPLETE
1	86198080	52-501576	1	BODY, WD HDL PORT		
2	86198170	52-501577	1	HOLD DOWN, WD HDL PORT		
3	86265730	04-000053	2	TIE, CABLE 8" WHT		
4	86183710	10-805330	1	HOSE, 3/16X13-3/4 (1/8PX1/4)		
4A	86184000	10-805397	1	HOSE, 3/16X7-1/2 (1/8P X 1/4F)		
5	86194410	17-803002	1	TIP, SPRY 9502X1/8P SST		
6	86273310	00-000282	2	SCR, CAP 1/4-20 X 1-1/4 SOC		
7	86177650	12-800060	1	CONN, 1/4P X 1/4T BR		
8	86192030	00-000317	3	SCR, CAP 10-32X1-1/4 SOCH		
9	86270990	57090	3	NUT, 10-32 HEX NYLOCK SS		
10	86174120	61-950496	1	ASSY, EXTRCTR VLV		
11	86247680	56015	1	NIPPLE, 1/4 HEX		
12	86005580	56012	1	NIPPLE, 1/4 FPT QD		
13	86194650	52-501619	1	TRIGGER, WD VLV		
14	86280020	09-805359	1	SLEEVE, WD HDL 9.5		
14A	86040950	09-805504	1	SLEEVE, STAIR TL HDL 7-1/8		
15	86183160	16-808229	1	HOLDER, VLV STEM-EXTRCTR VL		
16	86189520	43-810063	1	O-RING, .551 ID .691 OD		
17	86192410	16-808228	1	SEAT, EXTRCTR VLV		
18	86193360	16-808189	1	STEM, EXTRCTR VLV		
19	86174500	43-810064	1	BACK-UP, .250DIA		
20	86189510	43-810062	1	O-RING, .114 ID .254 OD		
21	86193200	16-808190	1	SPRING, EXTRCTR VLV		
22	86174630	52-501590		BODY, EXTRCTR VLV		
-	86178970	48-941163		DECAL, STAIR TL		
-	86186160	66-808169		KIT, REP-WD VLV		INCLUDES PARTS 16-19 & 20-22

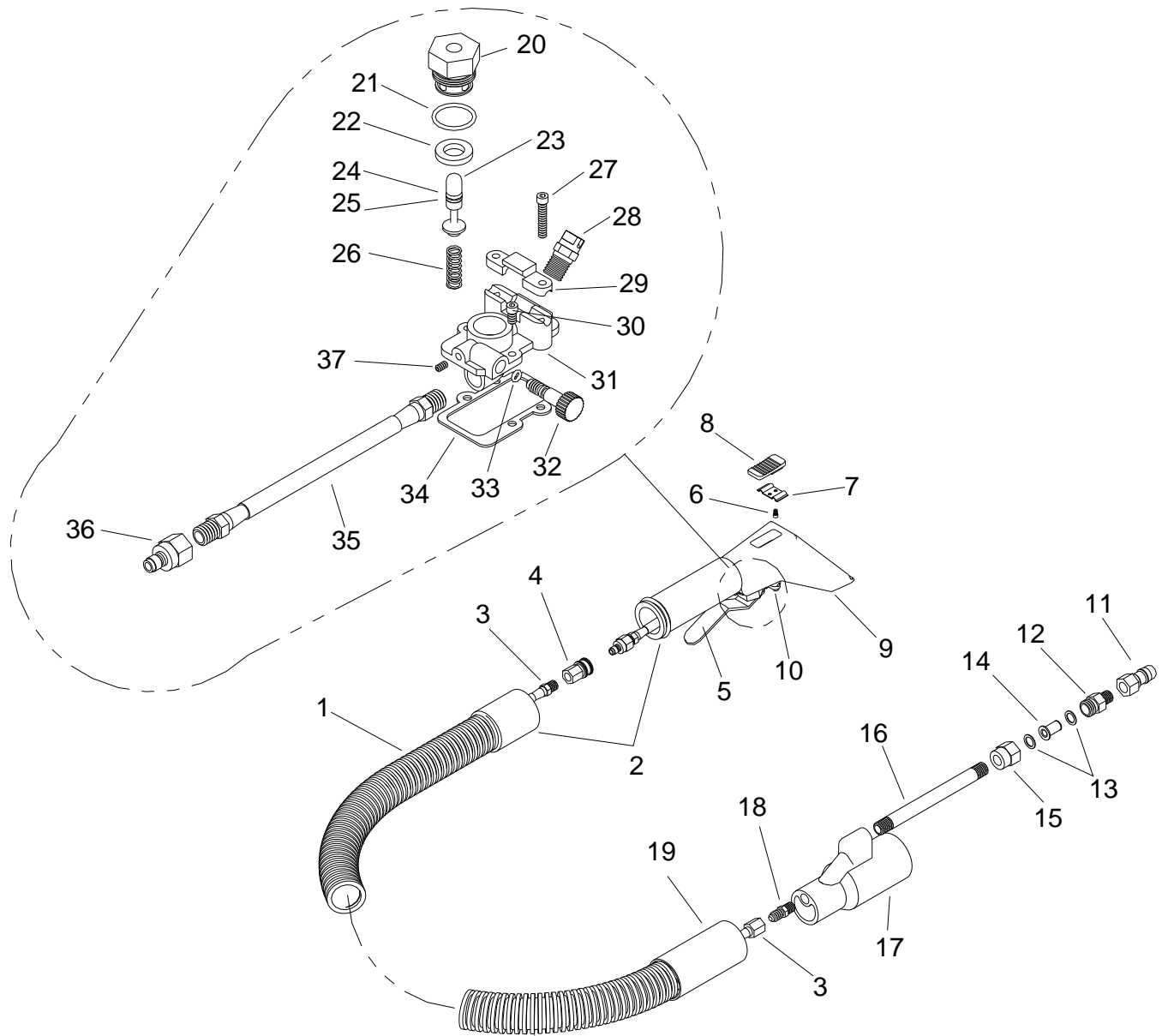

REF	PART NO.	PRV NO.	QTY	DESCRIPTION	SERIAL NO. FROM	NOTES:
-	86285260	78513	1	TL, UPHOLST, PC (80015)		COMPLETE
1	86280240	09-805131	2	HOSE, VAC 1-1/4X10' BLU		
2	86178660	08-805243	1	CUFF, SWIV 1-1/4HX1-1/4T		
3	86184670	10-805347	1	HOSE, 3/16X119-1/2 (1/8PX1/4FT)		
4	86179720	13-806023	1	DSC, 1/8FC1/8FP SST		
5	86178550	58-500639	1	UPHOLSTERY TL TRIGGER		
6	86273370	00-000310	1	SCR, CAP 4-40 X7/32 SHCS SS		
7	86193050	04-000282	1	SPRING, VAC ADJ BUTT		
8	86176080	52-501624	1	BUTTON, VAC ADJ		
9	86194590	52-501842	1	TOOL, UPHOLSTERY		
10	86174140	61-950570	1	ASSY, UPHLST TL VLV		INCLUDES PARTS 20-26, 28, & 31- 37
11	86005580	56012	1	NIPPLE, 1/4 NPT QD		
12	86177860	17-803010	1	CONN, 1/4P X 11/16-16M		
13	86195570	17-803006	1	WASHER, NYLON		
14	86193490	14-806512	1	STRAINER, JET 50MESH		
15	86177870	17-803036	1	CONN, 1/4FPX11/16-16F BR		
16	86188320	11-800404	1	NIP, 1/4X5 SST		
17	86178520	52-501585	1	COUPLER, UPHLST TL		
18	86177660	12-800065	1	CONN, 1/8P X 1/4T		
19	86178630	08-805138	1	CUFF, 1 1/4H X 1 1/2T GRY		
20	86183160	16-808229	1	HOLDER, VLV STEM-EXTRCTR VL		
21	86189520	43-810063	1	O-RING, .551 ID .691 OD		
22	86192410	16-808228	1	SEAT, EXTRCTR VLV		
23	86193360	16-808189	1	STEM, EXTRCTR VLV		
24	86174500	43-810064	1	BACK-UP, 250DIA		
25	86189510	43-810062	1	O-RING, .144 ID .254 OD		
26	86189510	16-808190	1	SPRING, EXTRCTR VLV		
27	86273350	00-000306	2	SCR, 6-32 X 1 SCHD SS		
28	86194500	17-803033	1	TIP, SPRY 80015X1/8P SST		
29	86178540	58-500638	1	CSTG, TRIGGER CLMP		
30	86273360	00-000307	2	SCR, CAP 6-32X3/8 SOCHD		
31	86195210	52-501623	1	VALVE, UPHLST TL		
32	86195530	52-501626	1	VALVE, ADJ-UPHLST TL VLV		
33	86189460	43-810016	1	O-RING, 5/32IDX9/32OD VIT		
34	86182570	43-807513	1	GASKET, UPHLST TL VLV		
35	86183770	10-805348	1	HOSE, 3/16X6-1/2 (1/8P BS)		
36	86179740	13-806030	1	D SC, 1/8MX1/8FP SST		
37	86192070	00-000408	1	SCR, SET 3-32 X 1/4 SOCHD		
-	86178980	48-941164	1	DECAL, UPHLST TL		
-	86186160	66-808169	1	KIT, REPAIR-WAND VLV		INCLUDES PARTS 20-22 & 24-26

Shelf Assembly - Optional

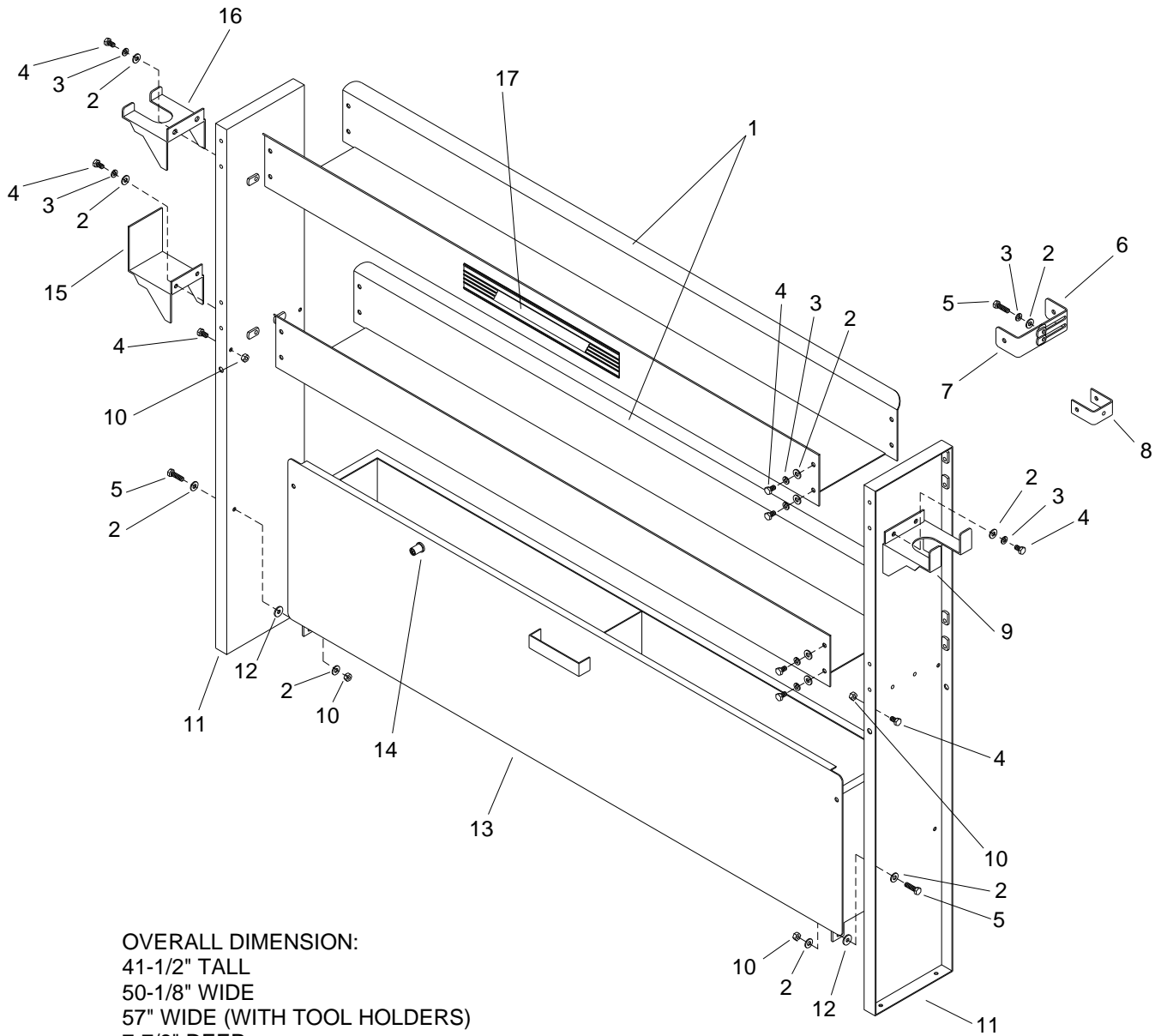

OVERALL DIMENSION:
 41-1/2" TALL
 50-1/8" WIDE
 57" WIDE (WITH TOOL HOLDERS)
 7-7/8" DEEP

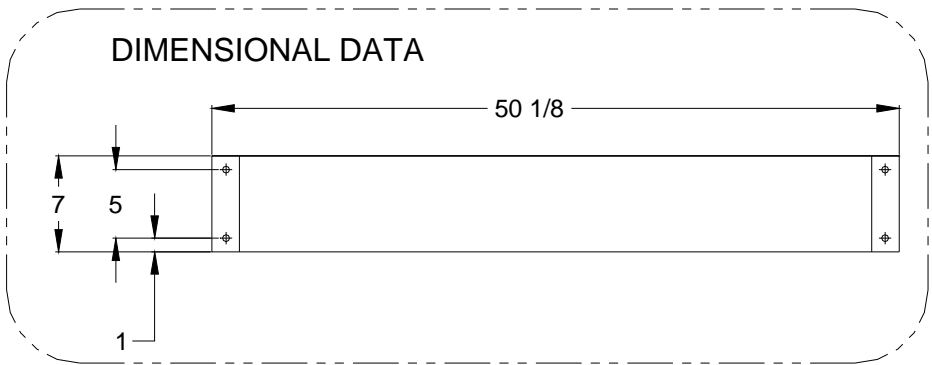

REF	PART NO.	PRV NO.	QTY	DESCRIPTION	SERIAL NO. FROM	NOTES:
-	86285410	65-950392	1	VAN STORAGE UNIT		COMPLETE
1	86192680	56-501921	1	SHELF, LWR		
2	86270330	02-000066	20	FLATWASHER, 1/4		
3	86010780	87162	20	WASHER, 1/4 SPLIT LOCK		
4	86274760	70271	20	SCR, 1/4-20 X 1/2 HHCS PLTD		
5	86274750	70270	4	SCR, 1/4-20 X 3/4 HHCS PLTD		
6	86175710	50-501840	1	BRKT, ADJUST MTG SLOT		
7	86175730	56-502067	1	BRKT, ADJUST MTG HLDR		
8	86198090	56-501942	1	BRKT, SHELF MOUNTING		
9	86285120	41460	1	HOLDER, STAIR TOOL		
10	86270620	01-000105	4	LOCK NUT, 1/4-20 HXHD		
11	86024890	56-501922	2	PANEL, SHLF END		
12	86278840	50-501749	2	WASHER, NYLON		
13	86021920	56-501920	1	DRAWER, SHELF GRAY		
14	86186850	46-802506	1	LATCH, ADJ GRIP		
15	86183180	50-501755	1	HOLDER, UP TL HOSE		
16	86183170	50-501754	1	HOLDER, UPHST TL		
17	86179350	48-941152	1	DECAL, PROCHEM		
-	86162440	66-945424	1	KIT, ADJ BRKT.		INCLUDES PARTS 6,7 & MOUNTING HARDWARE

Water Tank Dual with Demand Pump - Optional

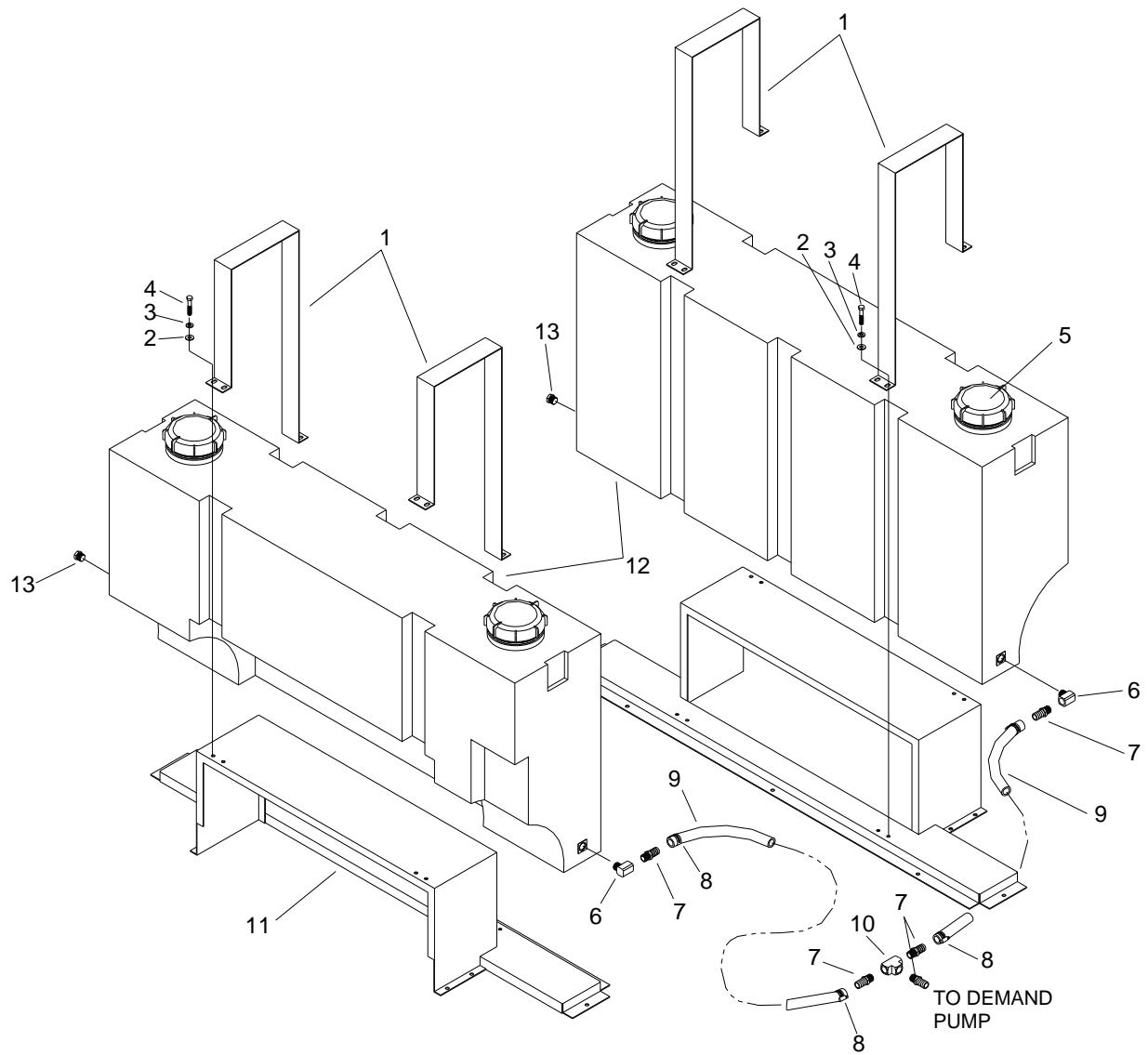

OVERALL DIMENSION:
 32-1/2" TALL
 62-5/8" WIDE
 15-1/2" DEEP

DIMENSIONAL DATA

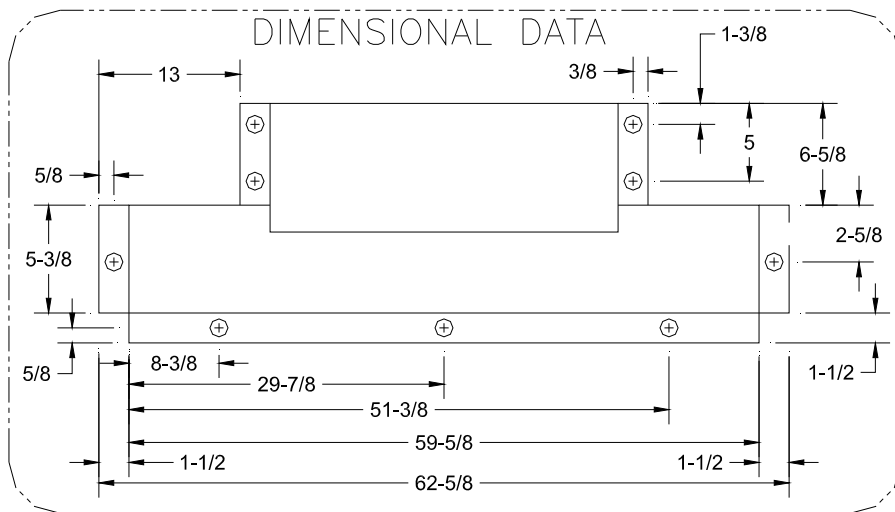

MOUNTING DETAIL

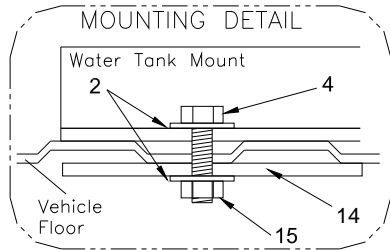

Water Tank Dual with Demand Pump - Optional

REF	PART NO.	PRV NO.	QTY	DESCRIPTION	SERIAL NO. FROM	NOTES:
-	86041730	66-945260	-	TANK, DUAL SADDLE W/DMD PUMP		COMPLETE
-	86041710	66-945265	-	SINGLE SADDLE TANK W/DMND PMP		COMPLETE
1	86048310	50-501774	4	HOLD DOWN, SADDLE TANK GRAY		
2	86279510	87171	16	WASHER, 3/8 FLAT		
3	86010790	87163	16	WASHER 3/8 SPLIT LOCK		
4	86277830	00-000072	16	SCR, 3/8-16 X 2' HXHD		
5	86176400	11-800432	4	CAP, WATER BOX		
6	86180170	11-800041	2	ELL, STREET 1/2 BR		
7	86181370	12-800278	5	FTTG, BRB 1/2P X 3/4H BR		
8	86177020	03-000113	4	CLAMP, HOSE #12 SST		
9	86280590	09-805456	1	HOSE, WTR 3/4 X 96		
10	86194120	11-800085	1	TEE, 1/2 BRASS		
11	86043320	56-502000	2	ASSY, BASE SADDLE TANK GRAY		
12	86030990	58-500661	2	MOLDING, WATER TANK		
13	86190500	11-800168	2	PLUG, 1/2 BRASS HXHD		
14	86190170	50-500511	8	PLATE, INSTALL MT		
15	86005770	57119	9	NUT, 3/8-16 HEX NYLOCK		
-	86285190	41458	1	SHLR, CHEM, 10-GAL JUG		

Water Tank - Demand Pump - Optional

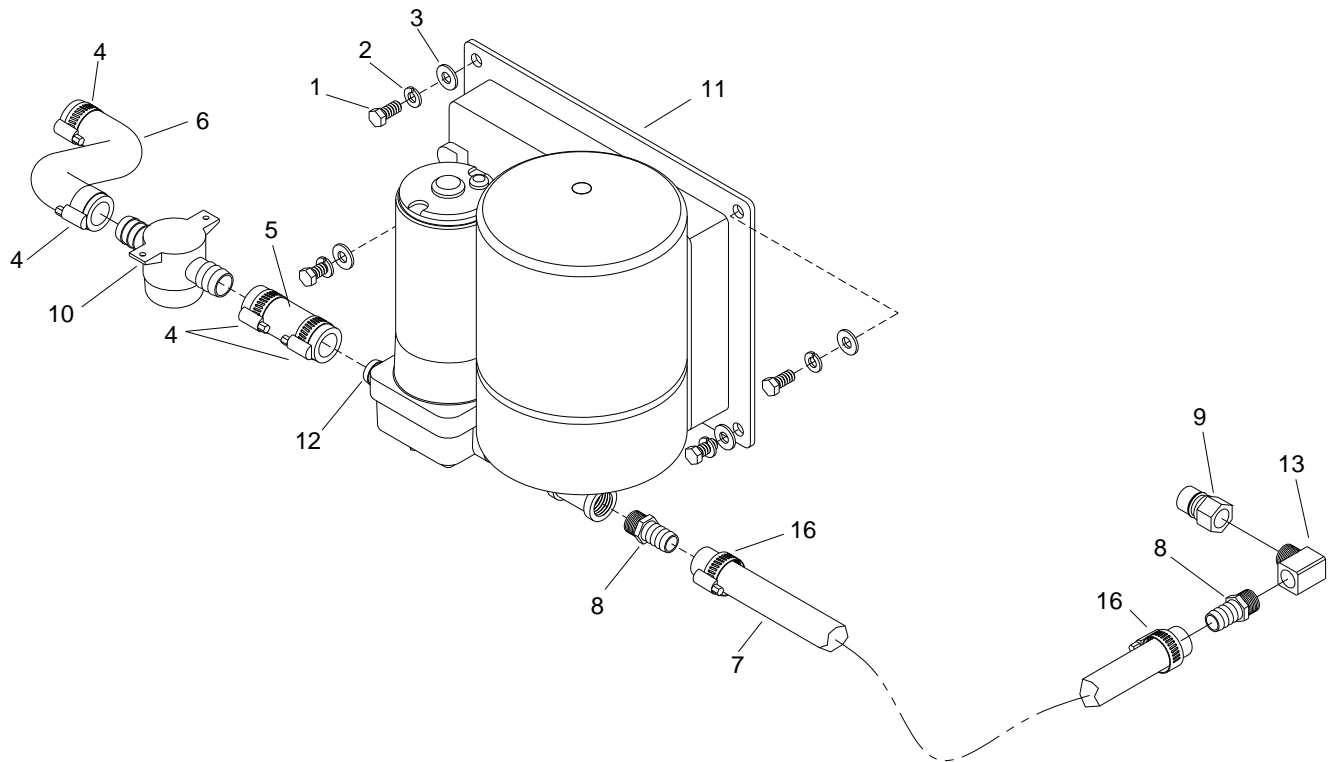

REF	PART NO.	PRV NO.	QTY	DESCRIPTION	SERIAL NO. FROM	NOTES:
-	86191390	65240	1	PUMP ONLY, TM DEMAND		
-	86186030	47449	1	KIT SERVICE DEMAND PMP		
1	86006760	70305	4	SCR, 5/16-18 X 3/4 HHCS GR5 PL TDL		
2	86279130	87083	4	WASHER, 5/16 SPLIT LOCK PLTD		
3	86278830	02-000143	4	WASHER, 5/16 FLAT		
4	86177020	03-000113	4	CLAMP, HOSE #12 SST		
5	86280290	09-805278	1	HOSE, WATER 3/4 X 3"		
6	86280420	09-805357	1	HOSE, WATER .75 X 5.5		
7	86280550	09-805446	1	HOSE, 5/8ID BLU X 55"		
8	86181400	12-800345	1	FTTG, BRB 3/8P X 5/8H BR		
9	86179630	13-806009	1	DISCONNECT, 3/8M X 3/8FP		
10	86180900	14-806553	1	FILTER, DEMAND PUMP		
11	86190740	41-905049	1	PUMP, WATER BOOSTER		
12	86186120	48-809423	1	KIT, PORT		
13	86180210	11-800275	1	ELBOW, ST 3/8 BR		
14	86177060	03-000246	2	CLAMP, HOSE #8 SST		

Auxiliary Water Tank with Pump-Optional

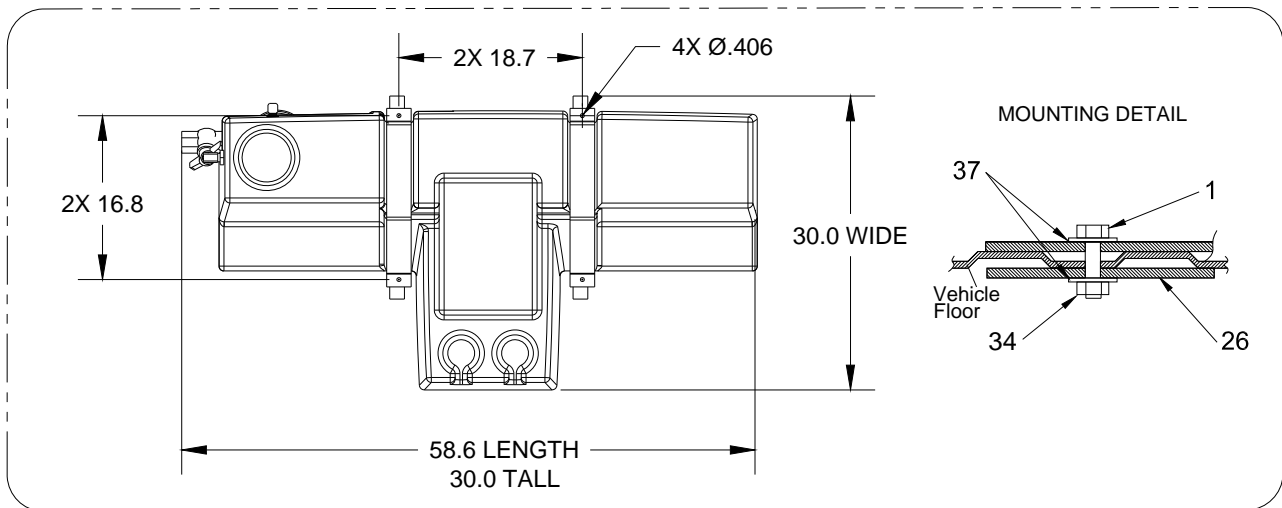
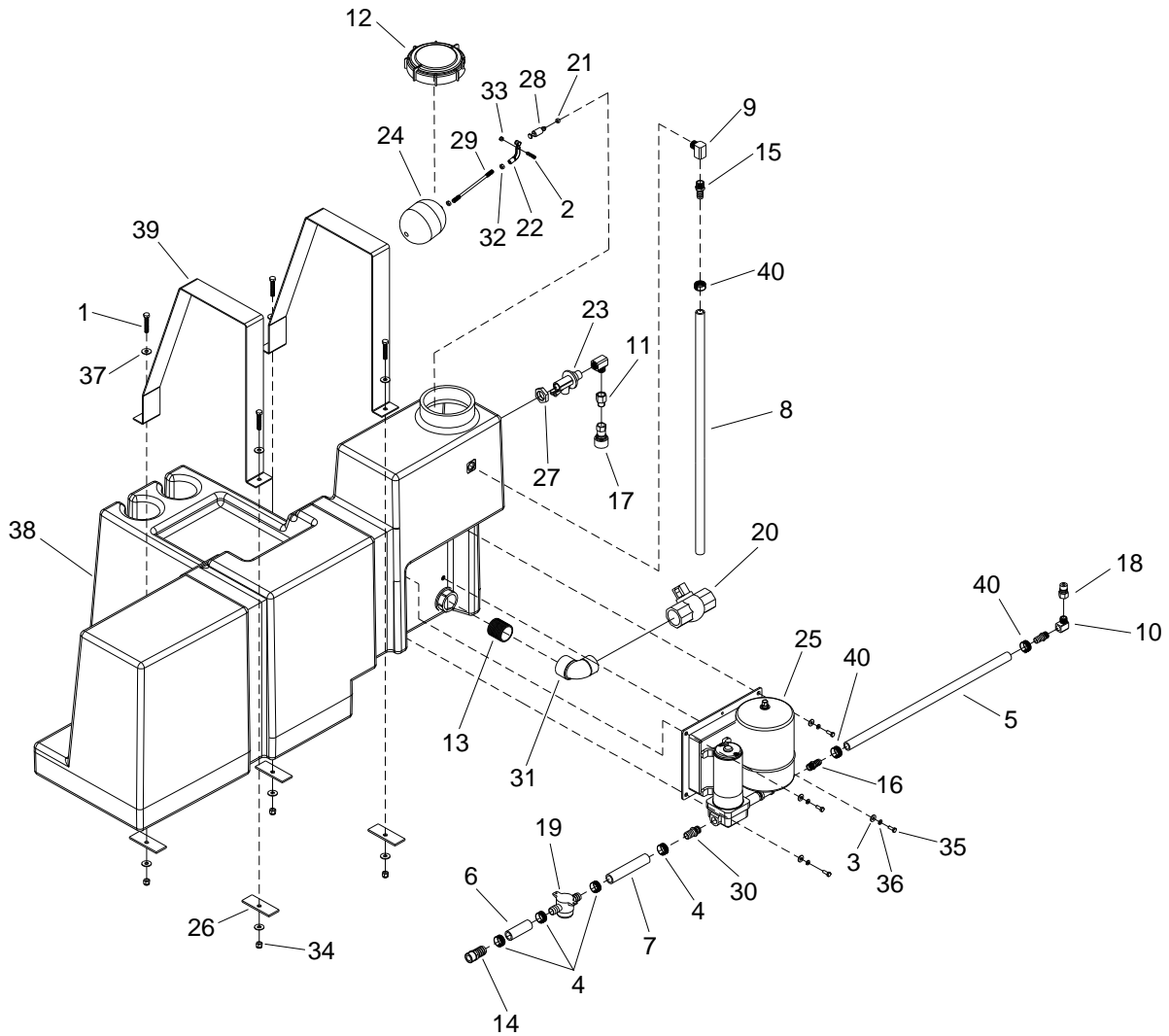

Auxiliary Water Tank with Pump-Optional

REF	PART NO.	PRV NO.	QTY	DESCRIPTION	SERIAL NO. FROM	NOTES:
-	86041580	790821	1	ASSY, AUX WTR TNK W/PMP		COMPLETE
1	86277830	00-000072	4	SCR, 3/8-16 X 2" HXHD		
2	86277850	00-000337	1	SCR, 10-32 X 1" SOCHD SST		
3	86270330	02-000066	4	FLATWASHER, 1/4		
4	86177020	03-000113	4	CLAMP, HOSE #12 SST		
5	86280550	09-805446	1	HOSE, 5/8 ID BLU X 55"		
6	86280290	09-805278	1	HOSE, 3/4 ID WTR X 3"		
7	86280420	09-805357	1	HOSE, 3/4 ID WTR X5.5"		
8	86280140	09-805406	1	HOSE, 5/8 ID BLU X 30 1/2		
9	86180170	11-800041	2	ELL, STREET 1/2 BR MACH		
10	86180210	11-800275	1	ELL, ST 3/8 BR		
11	86191600	11-800283	1	RED, 1/2FP X 3/8P BR		
12	86176400	11-800432	1	CAP, WATER BOX		
13	86188470	11-800524	1	NIP, 1-1/2XCL PVC (SCH80)		
14	86181320	12-800095	1	FTTG, BRB 3/4PX3/4H BR		
15	86181360	12-800269	1	FTTG, BRB 1/2 X 5/8H BR		
16	86181400	12-800345	2	FTTG, BRB 3/8P X 5/8 BR		
17	86179710	13-806008	1	DISCONNECT 3/8F X 3/8FP		
18	86179630	13-806009	1	DISCONNECT 3/8M X 3/8FP		
19	86180900	14-806553	1	FILTER, DEMAND PUMP		
20	86195010	15-808080	1	VALVE, BALL PVC 1-1/2FP		
21	86192380	16-808164	1	SEAT, FLOAT VLV TM		
22	86173820	16-808216	1	ARM, PIVOT-FH VLV		
23	86174610	16-808217	1	BDY, FLOAT VLV		
24	86174540	19-807014	1	BALL, FLOAT		
25	86190740	41-905049	1	PMP, WTR BOOSTER FLOJET 2		
26	86190170	50-500511	4	PLATE, INSTALL MT		
27	86189010	52-501706	1	NUT, FLOAT VALVE		
28	86028860	52-800314	1	PISTON, FLOAT VLV PISTON		
29	86181150	54-501715	1	FLOAT ROD, TM		
30	86186120	48-809423	1	KIT, PORT DEMAND PUMP		
31	86180010	31100	1	ELBOW, 1.5 STREET PVC MP X FP		
32	86270770	57006	2	NUT, 1/4-20 HEX		
33	86270990	57090	1	NUT, 10-32 HEX NYLOCK SS		
34	86005770	57119	4	NUT, 3/8-16 HEX NYLOCK		
35	86274750	70270	4	SCR, 1/4-20 X 3/4 HHCS PLTD		
36	86010780	87162	4	WASHER, 1/4 SPLIT LOCK PLTD		
37	86279510	87171	8	WASHER, 3/8 FLAT		
38	86031000	790617	1	TANK, FRESH WATER 70GAL		
39	86057170	790666	2	STRAP, WTR TNK HOLD DOWN		
40	86177060	03-000246	3	CLAMP, HOSE #8 SST		

Hose Reel - Optional

DIMENSIONAL DATA

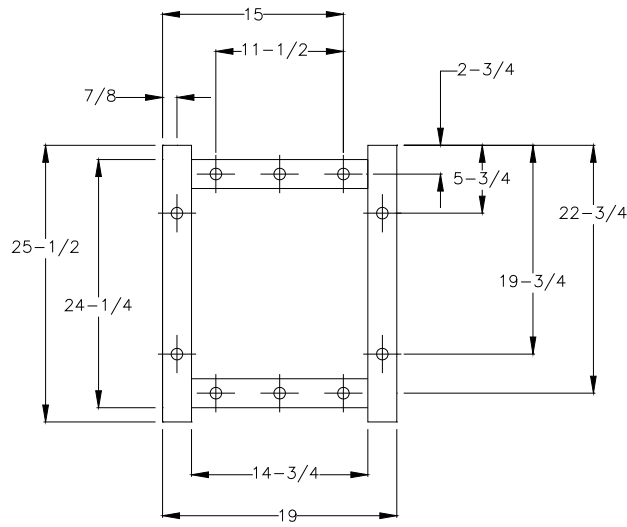
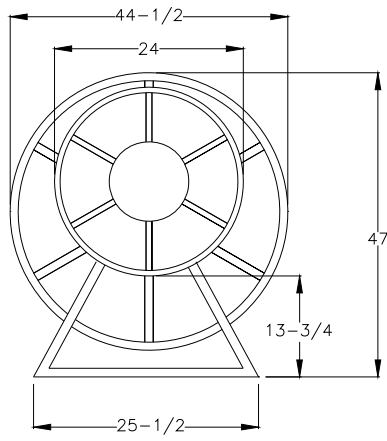

MOUNTING DETAIL

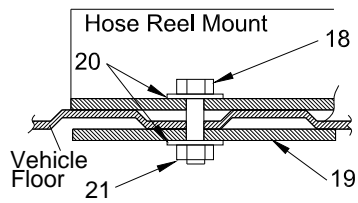

OVERALL DIMENSIONS:
47" TALL
29" WIDE
44-1/2" DEEP

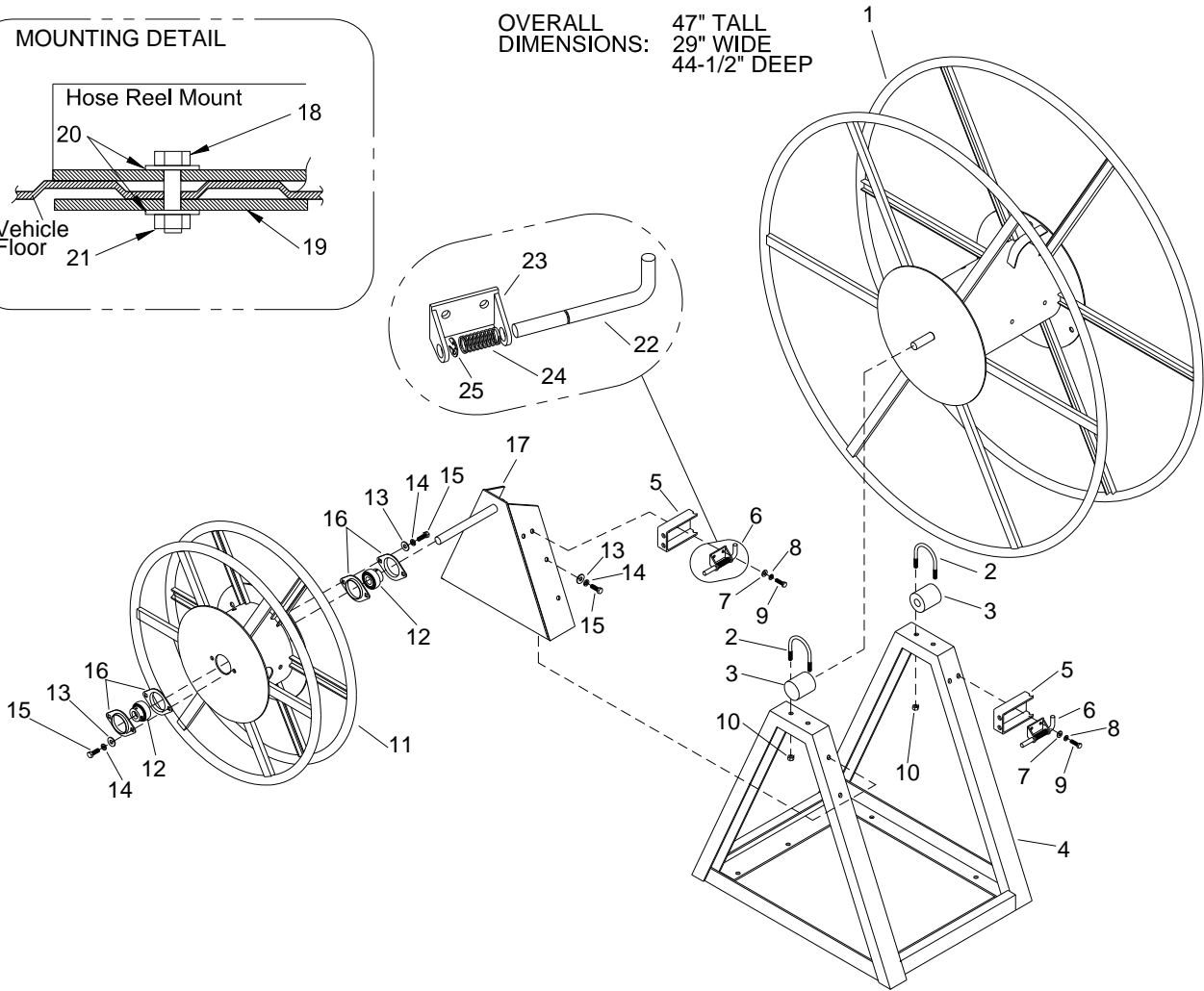

REF	PART NO.	PRV NO.	QTY	DESCRIPTION	SERIAL NO. FROM	NOTES:
-	86285140	65-950393	1	HOSE REEL, HIGH PROFILE PC		COMPLETE
1	86191620	56-501962	1	REEL, VACUUM HOSE GRAY		
2	86177270	03-000124	2	CLAMP, MFLR 1-3/4		
3	86175990	52-501685	2	BUSHING, HOSE REEL		
4	86174560	56-501960	1	BASE, HOSE RL (250')		
5	86175740	56-502207	2	BRKT, LOCKOUT HOSE REEL		
6	86186870	61-950854	2	LATCH ASSEMBLY		
7	86270330	02-000066	4	FLATWASHER, 1/4		
8	86010780	87162	4	WASHER, 1/4 SLPIT LOCK		
9	86274750	70270	4	SCR, 1/4-20 X 3/4 HHCS PLTD		
10	86005650	57031	2	NUT, 5/16-18 HEX		
11	86191820	56-501968	1	REEL, HP HOSE GRAY		
12	86174740	45-802138	2	BEARING HOSE REEL		
13	86278830	02-000143	4	FLATWASHER, 5/16		
14	86279130	87083	4	WASHER, 5/16 SPLIT LOCK PLTD		
15	86006750	70302	4	SCR, 5/16-18 X 1" HHCSGR5PLT		
16	86181030	44-802122	4	FLANGE, 47MST		
17	86174730	56-501961	1	BODY, HP HOSE GRAY		
18	86277830	00-000072	10	SCR, 3/8-16 X 2" HXHD		
19	86190170	50-500511	10	PLATE, INSTALL MT		
20	86279510	87171	10	WASHER, 3/8 FLAT		
21	86005770	57119	10	NUT, 3/8-16 HEX NYLOCK		
22	86189850	55-501789	2	PIN, LOCK HOSE REEL		
23	86175700	50-501812	2	BRKT, HOSE REEL LOCK		
24	86193240	04-000302	2	SPRING, LOCK-LOCK PIN ASSY		
25	86177190	04-000303	2	CLIP, RETAINER-LOCK PIN ASSY		

Wiring Diagram

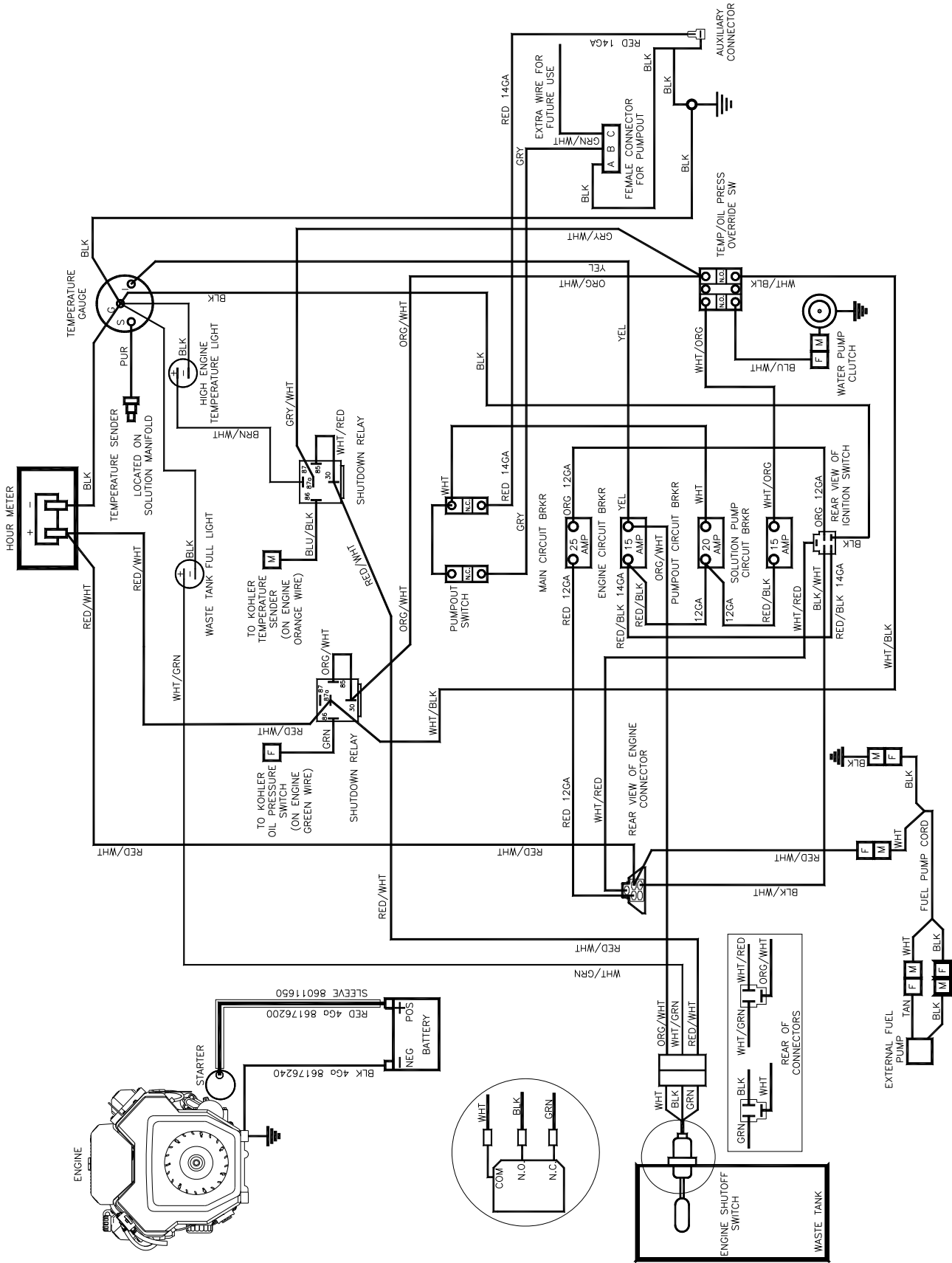

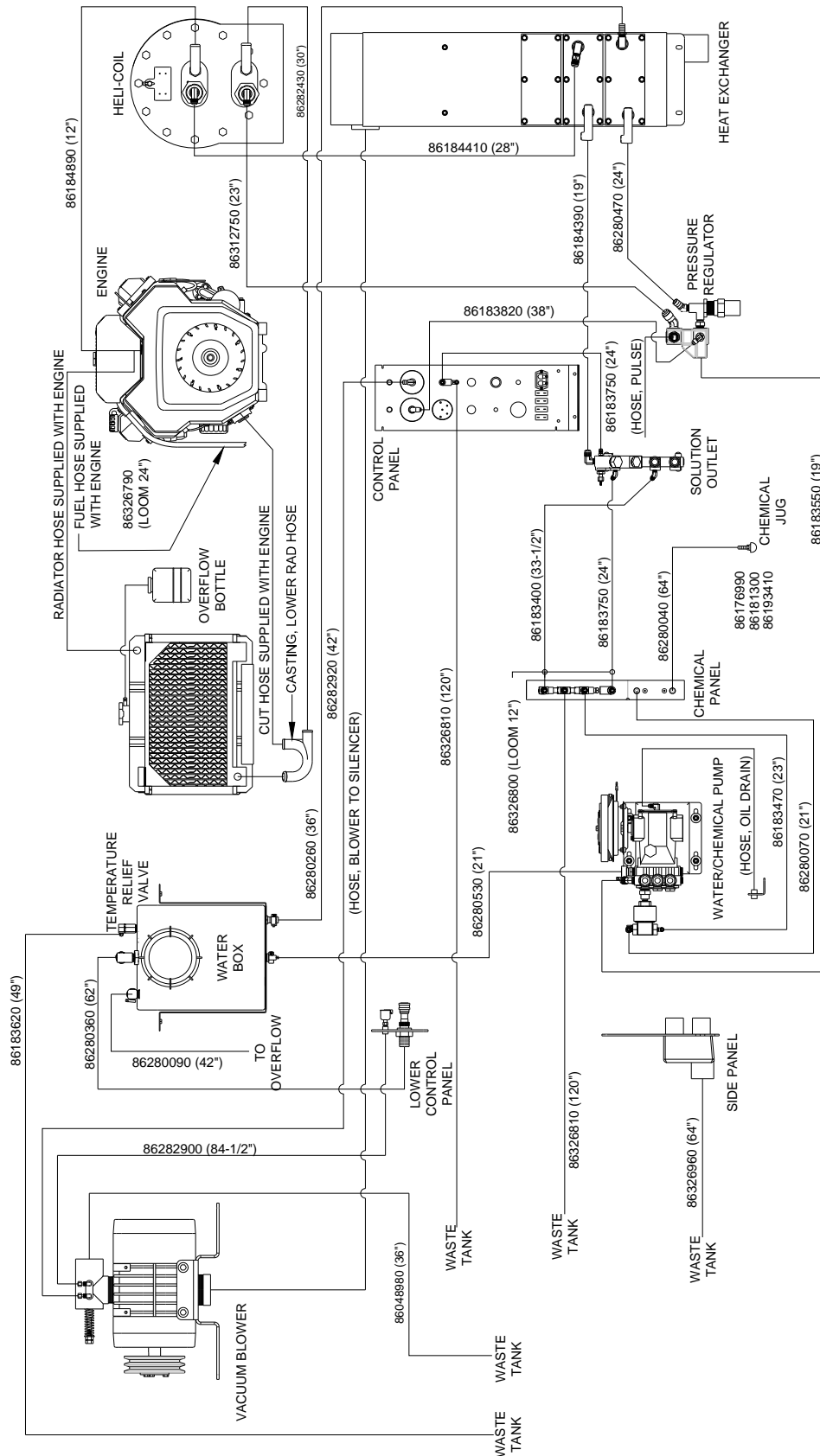

Notes:
